

# ➤ Instructions

## Thule Evo Raised Rail 7104

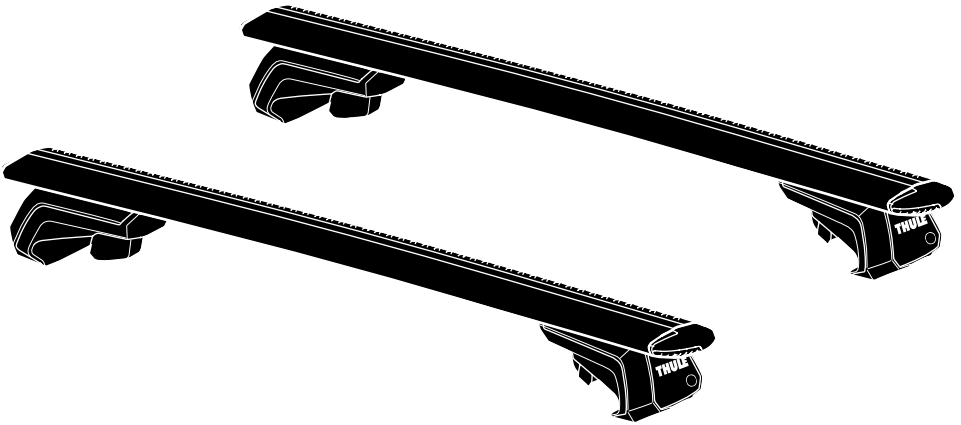

**EN** Roof mounted load carrier  
**DE** Lastenträger zur Dachmontage  
**FR** Barre de toit  
**NL** Dakdrager  
**IT** Barra portatutto da installare sul tetto  
**ES** Portaequipajes de techo  
**PT** Barra para montagem no tejadilho  
**SV** Takmonterad lasthållare  
**DK** Tagmonteret lastholder  
**NO** Takmontert lasteholder  
**FI** Katolle asennettava teline  
**ET** Katusele paigaldatav katuseraam  
**LV** Uz jumta uzstādāms kravas turētājs  
**LT** Ant stogo tvirtinamas krovinių laikiklis  
**PL** Uchwyt na bagażnik bazowy montowany na dachu  
**RU** Багажник на крышу  
**UK** Багажник для даху  
**BG** Багажник, монтиран върху покрива  
**CS** Nosič pro montáž na střechu  
**SK** Strešný nosič  
**SL** Nosilec za strešni prtljajnik

**HR/BIH** Krovni nosač tereta  
**RO** Suport încărcătură montat pe acoperiș  
**HU** Tetőre szerelhető csomagszállító  
**EL** Σχάρα οροφής για μεταφορά φορτίου  
**TR** Araç üstüne bağlanan yük taşıyıcı

**HE** מנשא מטען על הגג  
**AR** حامل نقل مثبت على السقف

**ZH** 顶置行李架  
**JA** ルーフマウント型ロードキャリア  
**KO** 루프 장착 화물 캐리어  
**TH** โครงยึดของบรรทุกแบบติดตั้งบนหลังคา

**CITY CRASH**  
 Complies with ISO norm

ISO 11154-E

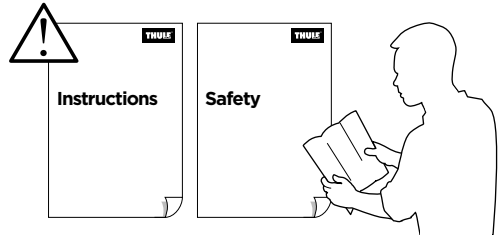

## >Mounting Tutorial

Thule Evo Raised Rail

**THULE**  
SWEDEN



thule.com

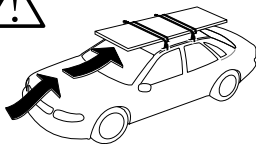

80 km/h  
50 Mph

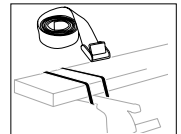
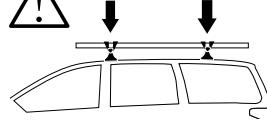
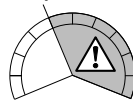

+ 1,8 kg + 4 kg + 5,5 kg + 10,6 kg = Max. 100 kg

**2**  
FOOT PACK

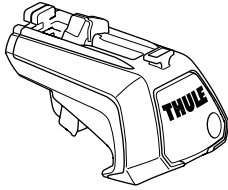

x4



x4



x2

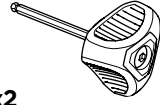

4 Nm

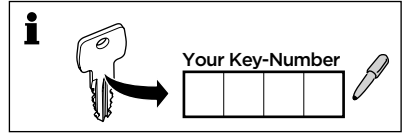

**3**  
BAR

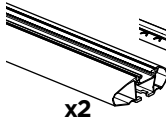

x2

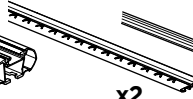

x2



x2



x2



x2

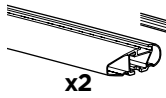

x2

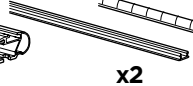

x2

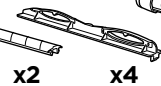

x2

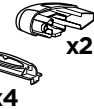

x2



x2

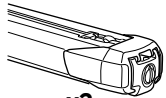

x2



x2



x2



x1



x2



x1

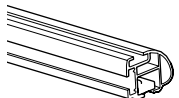

x2

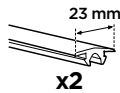

x2

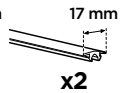

x2

x4

x4



x1



x2



x2

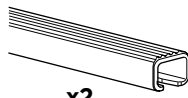

x2



x4

1

A

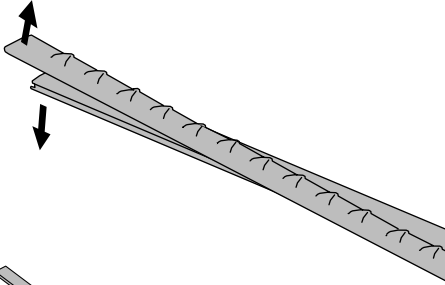

B

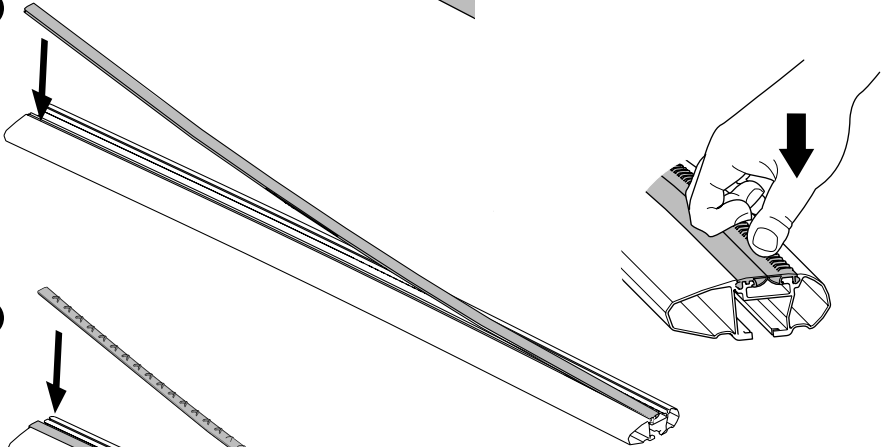

C

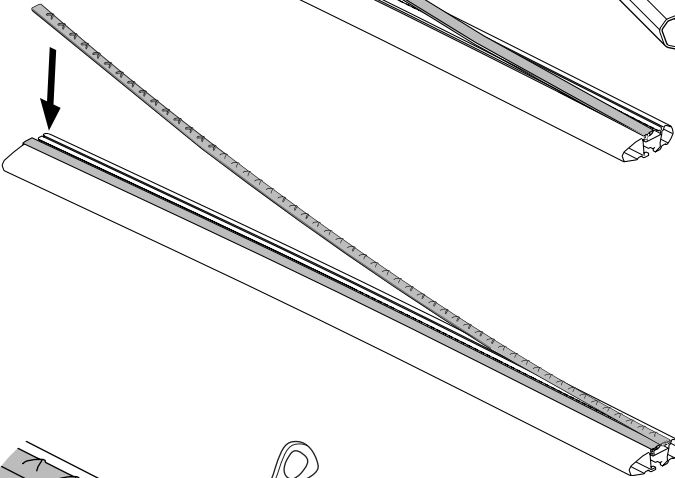

D

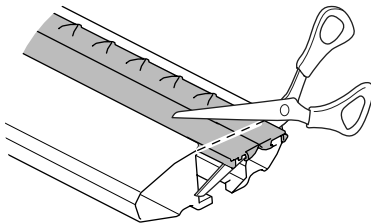

x2

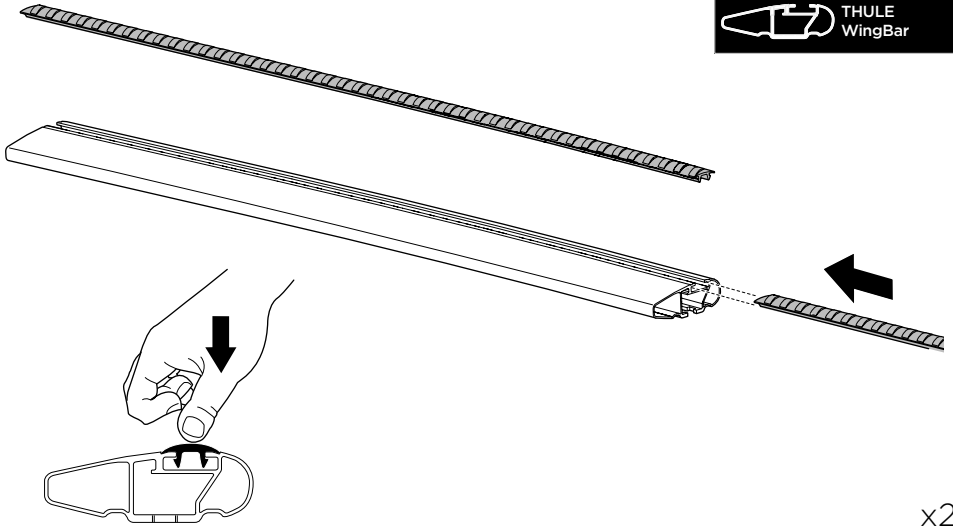

x2

2



A



B



C

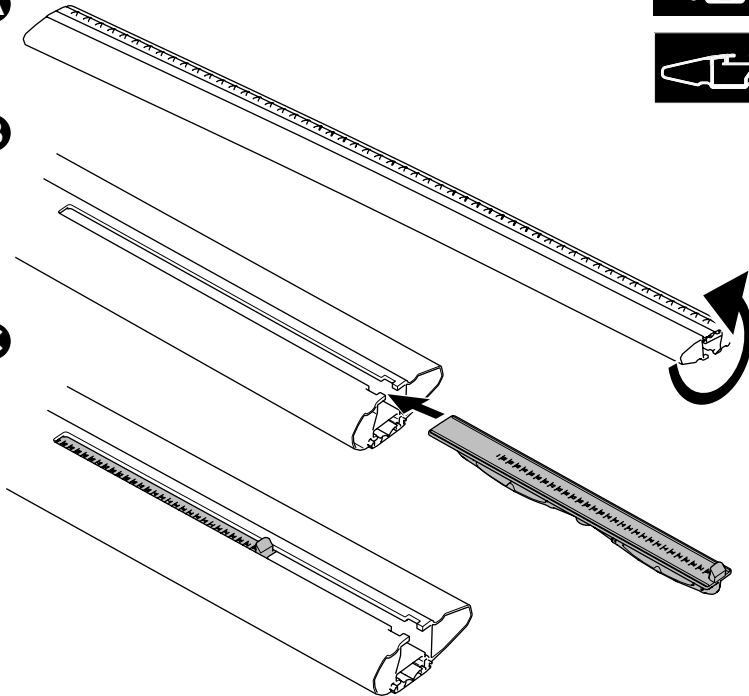

x4

3

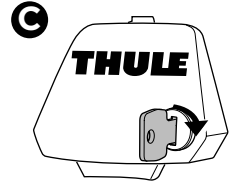
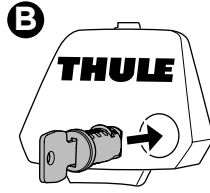
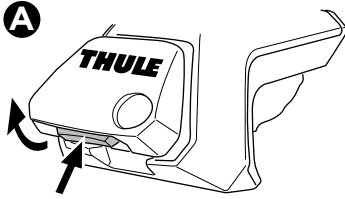

x4

4

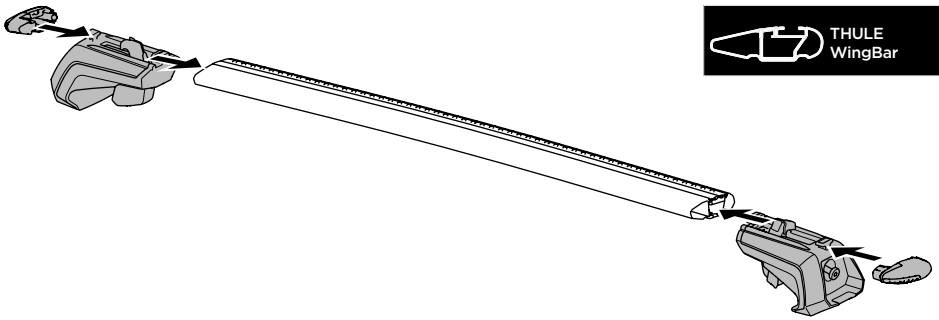

x2

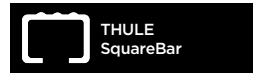
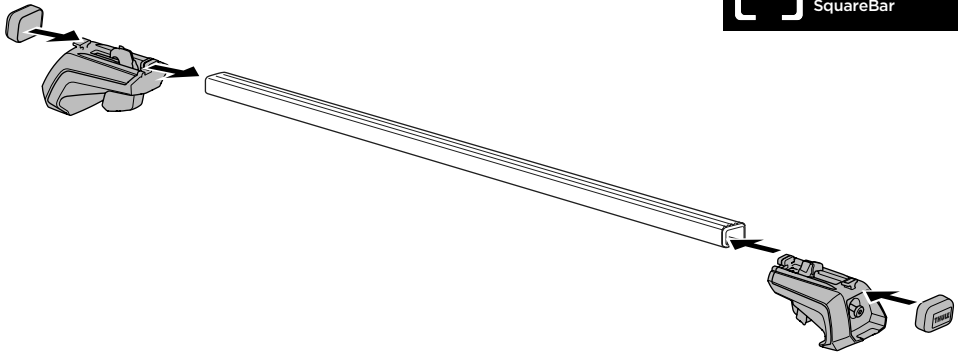

x2

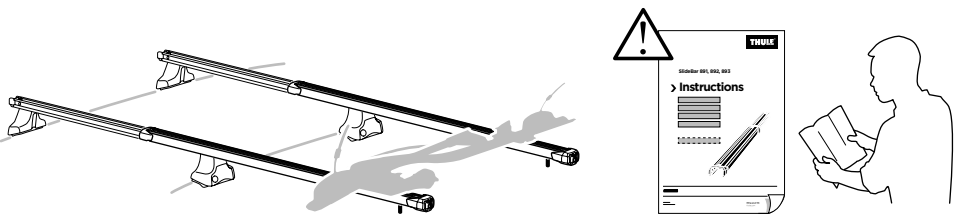
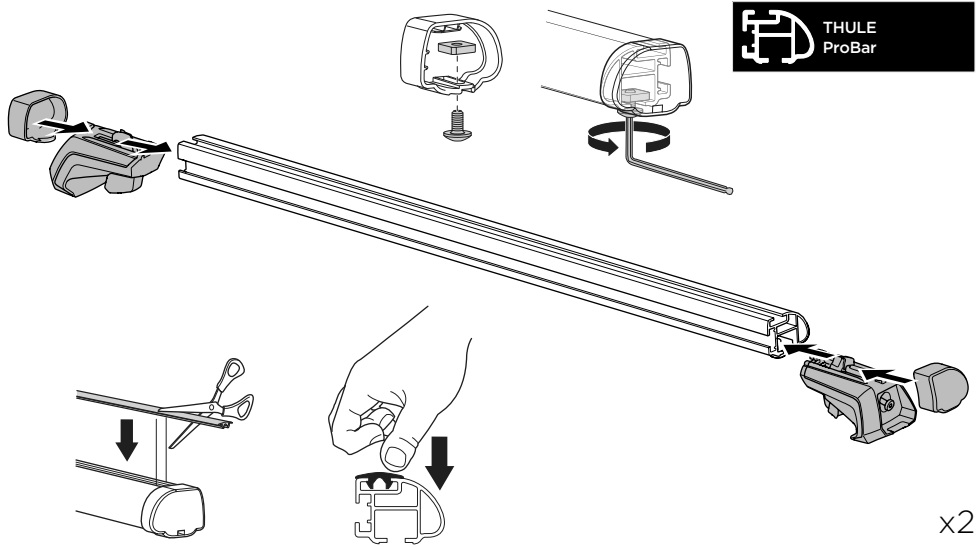

5

A

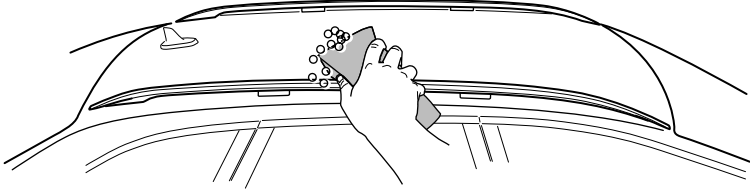

B

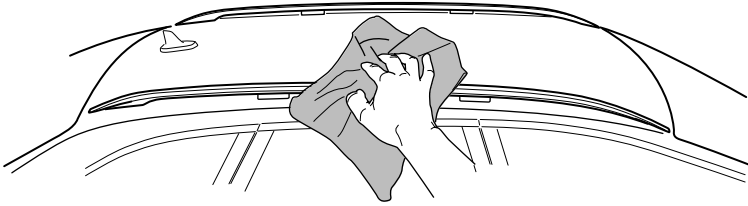

6

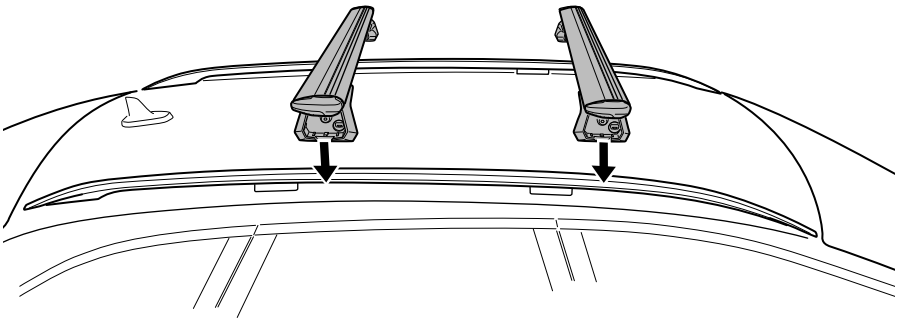
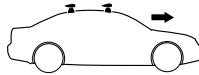



7

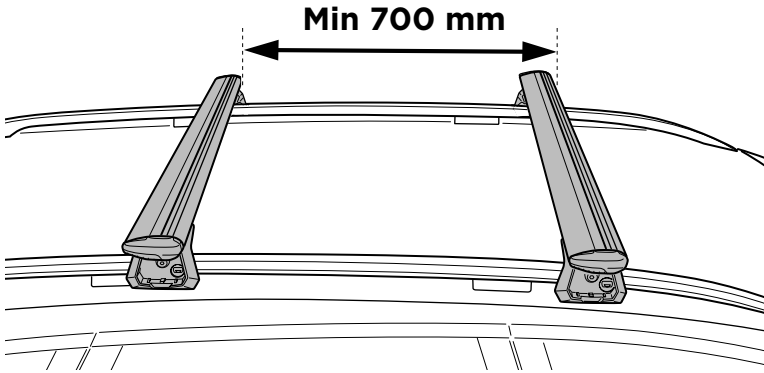

8

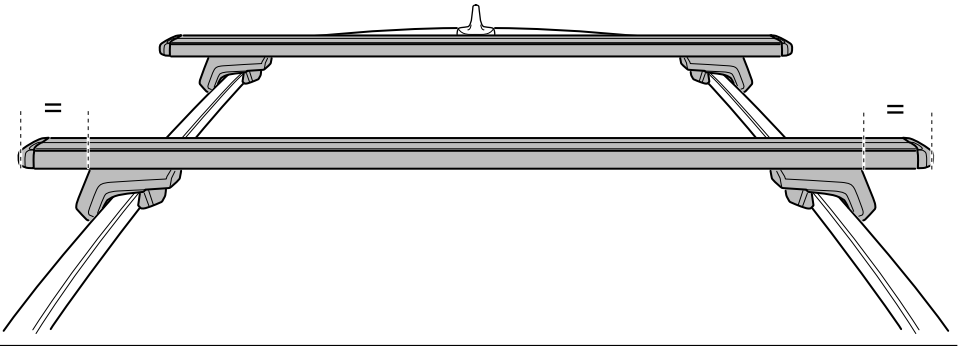

9

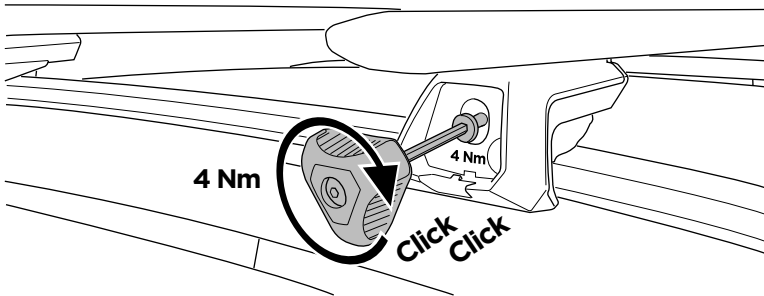

x4

10

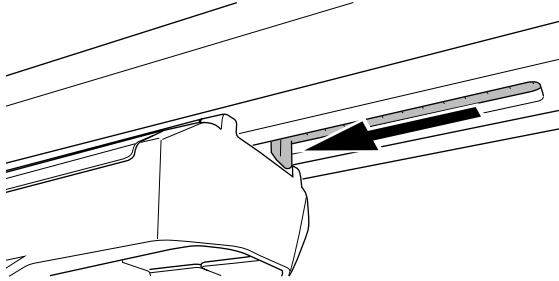

x4

11

A

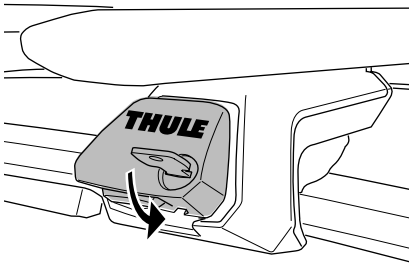

B

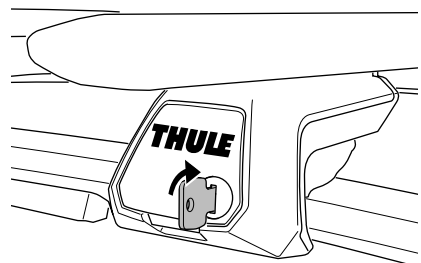

x4

12

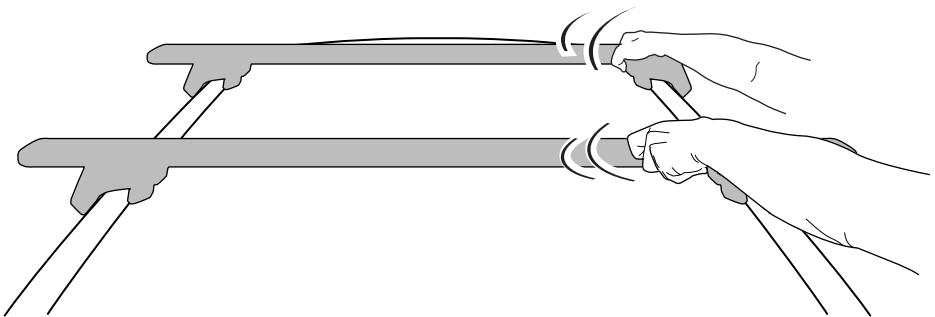

13

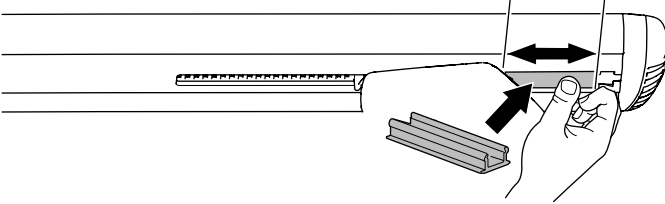
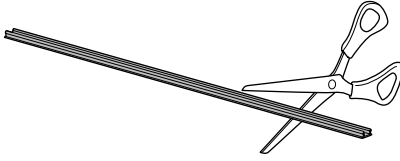

x4

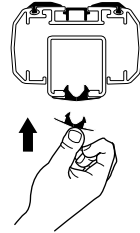
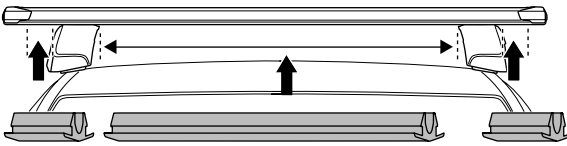
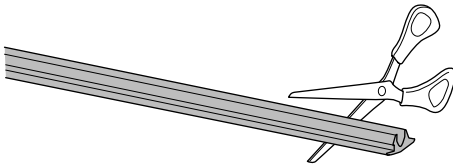

x2

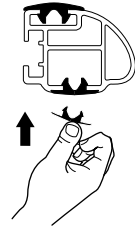
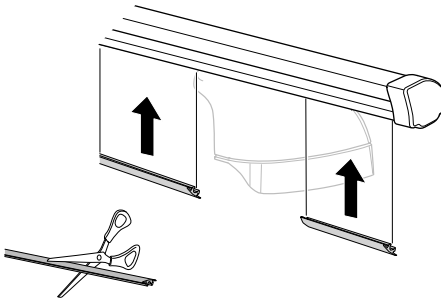
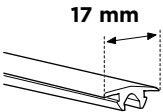

x2

**i**

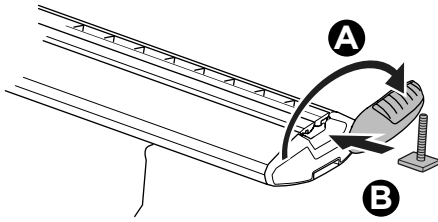

**THULE**  
WingBar Evo

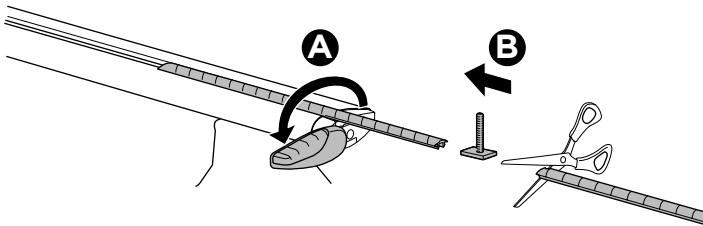
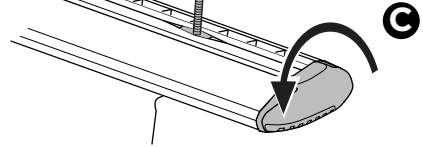

**THULE**  
WingBar

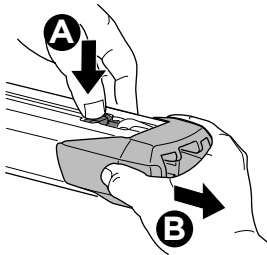

**THULE**  
SlideBar

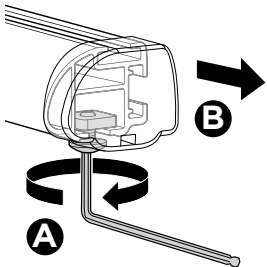
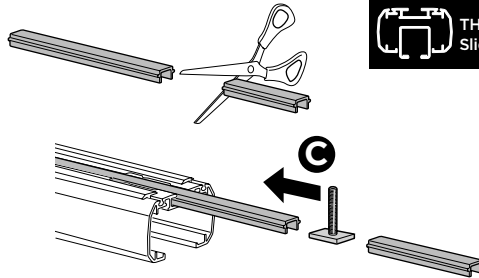

**THULE**  
ProBar

