

Quickstrap 552

5 *års garanti*
years warranty
Jahre Garantie
ans de garantie

552/1050-24-1

Components:

2 ratchet load stops complete with straps and assembly kit.

Materials:

Holders in yellow-chromed galvanized steel plate with plastic coating. Knobs and end covers in plastic. Fastenings in yellow-chromed, zinc-plated steel. Straps in blue polyester, L = 2 m.

Function:

For rapid and secure fastening of different types of load. The holders and fastenings should be secured to the load carrier, and the load then positioned under the straps and secured with the ratchets. The straps are unfastened by releasing the crank stop.

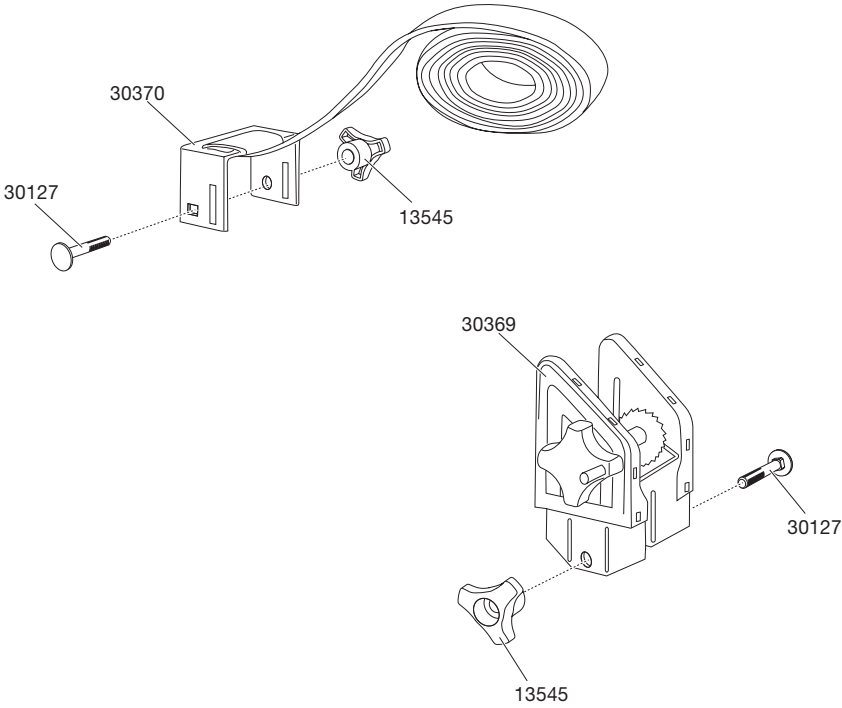

- Convenient ratchets incorporating load stops at one end
- Can be supplemented with cable lock article no: 538.
- Automatic crank stop
- TÜV/GS approved.



552 1050-24-1

410/1

Individual box	Pallet
----------------	--------

Product	EAN	Kg	L/W/H in cm
552	7 313021 052419	1,2	23/14/9

Product	Qty/kg	L/W/H in cm
552	10/12,5	48/24/31