

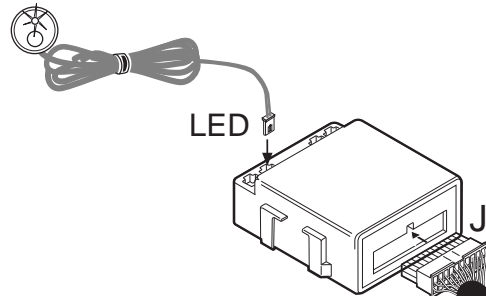

SÄKRINGARNA I SCHEMAT MEDFÖLJER EJ



LED

J

SVART J-8
RÖD J-9

J-17 BLÅ

See chapter 11

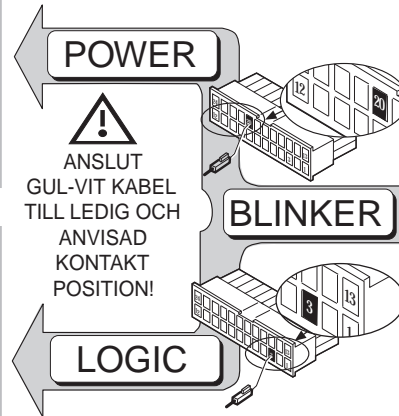
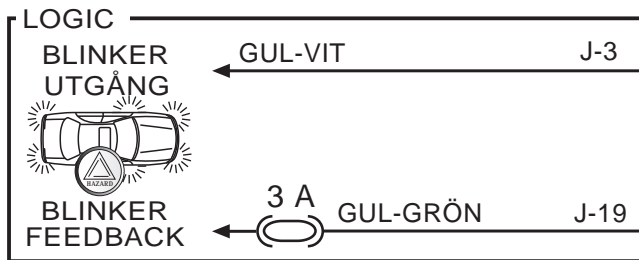
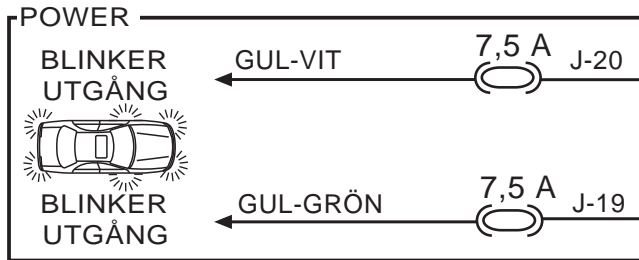
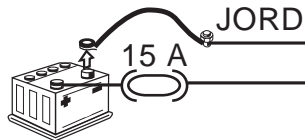

J-21 GRÖN

J-22 GRÖN

STARTMOTOR +50



max 20A (1 sek.)
6A kontinuerligt

J-12 ORANGE

J-11 LILA

ORANGE

CAN - H
CAN - L

LILA



SVART

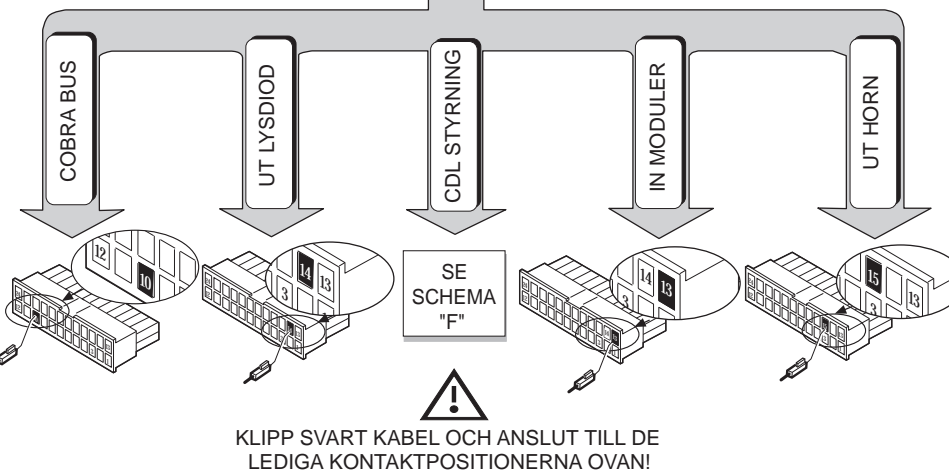

Se bilmodell Anpassad installationsmanual

●	GUL-SVART	J-18
●	ROSA-VIT	J-16
●	LILA-SVART	J-5
●	GRÅ-SVART	J-4
●	GRÖN-RÖD	J-7
●	BLÅ-ROSA	J-2
●	ORANGE-SVART	J-6
●	ROSA-BLACK	J-1

A

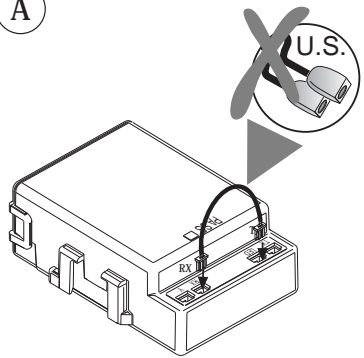

Anslut byglingen (03CA0445) mellan kontaktarna TX och RX för ultraljudsensorena, om du inte använder dessa.

B

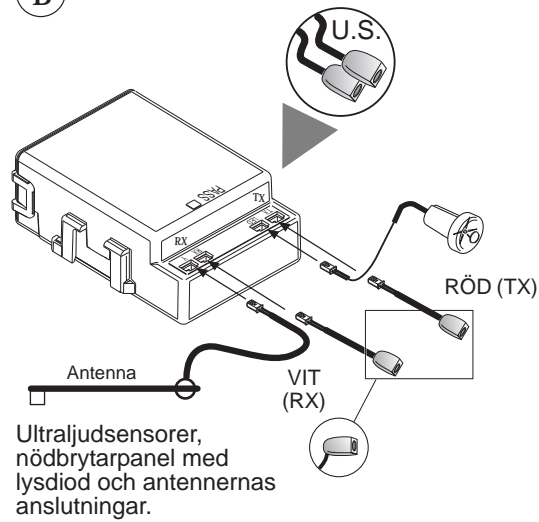

Ultraljudsensorer, nödbrytarpanel med lysdiod och antennernas anslutningar.

C

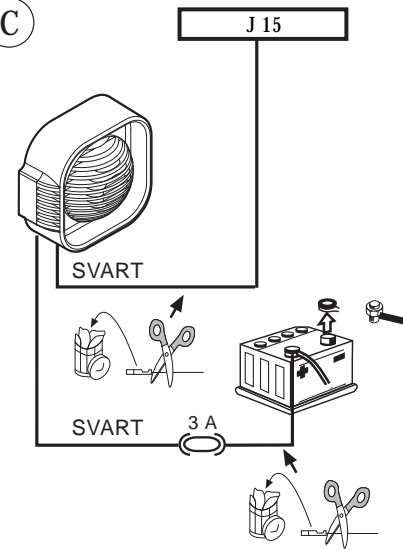

D

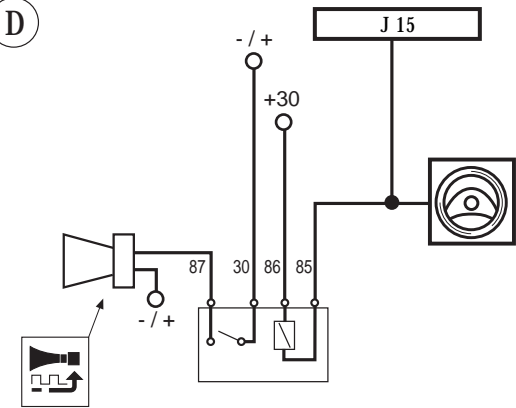

Original relä styrd av en jordsignal. Anslutning till fordonets signalhorn med negativ styrsignal till originalreläet.

E

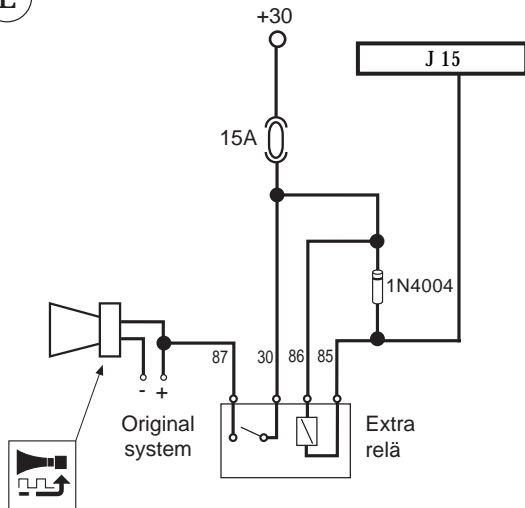

Anslutning till fordonets signalhorn med extra relä.

F

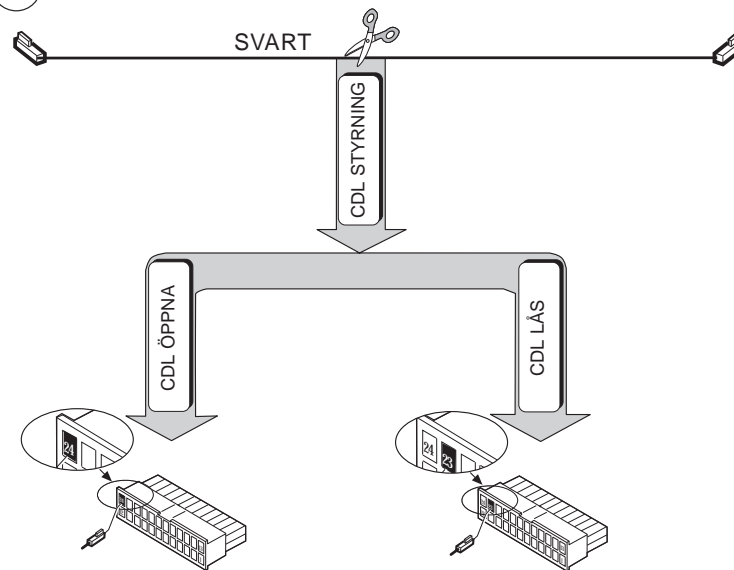

Centrallås (CDL) anslutningar (endast 4627)

G

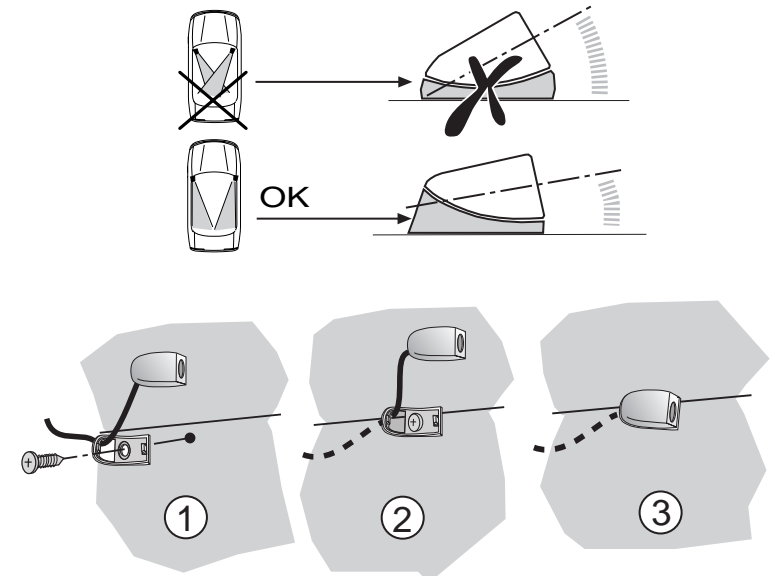

H

SIREN ANSLUTNINGAR EJ TRÅDLÖS

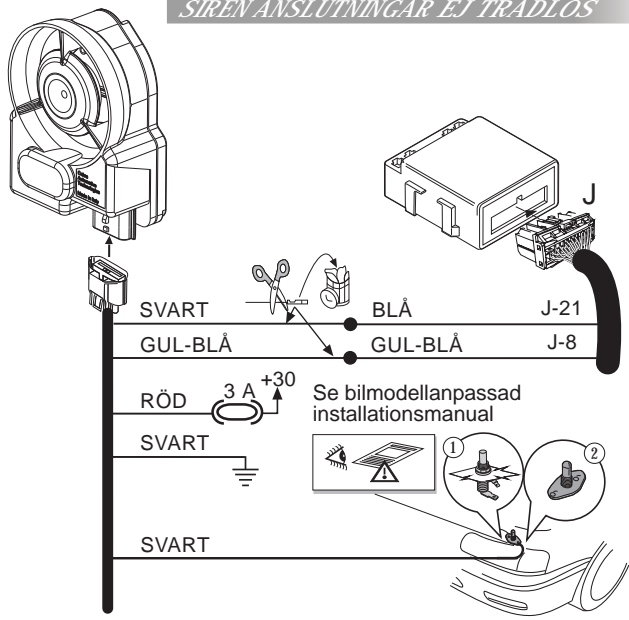

TRÅDLÖS SIREN ANSLUTNINGAR

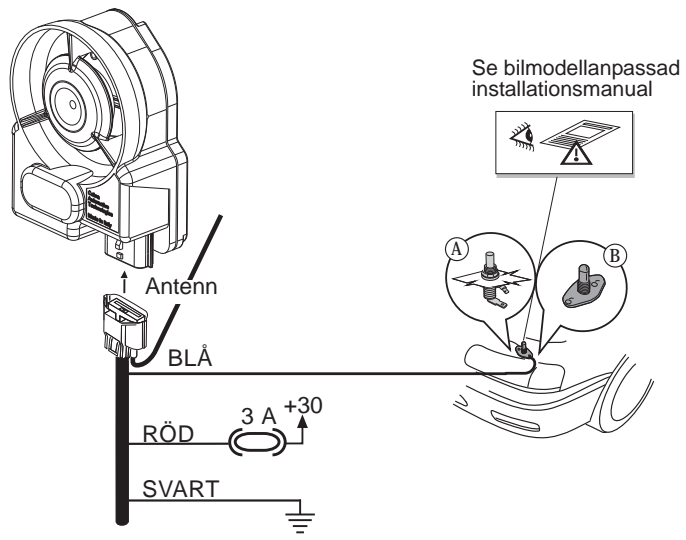

MOTORHUVKONTAKT

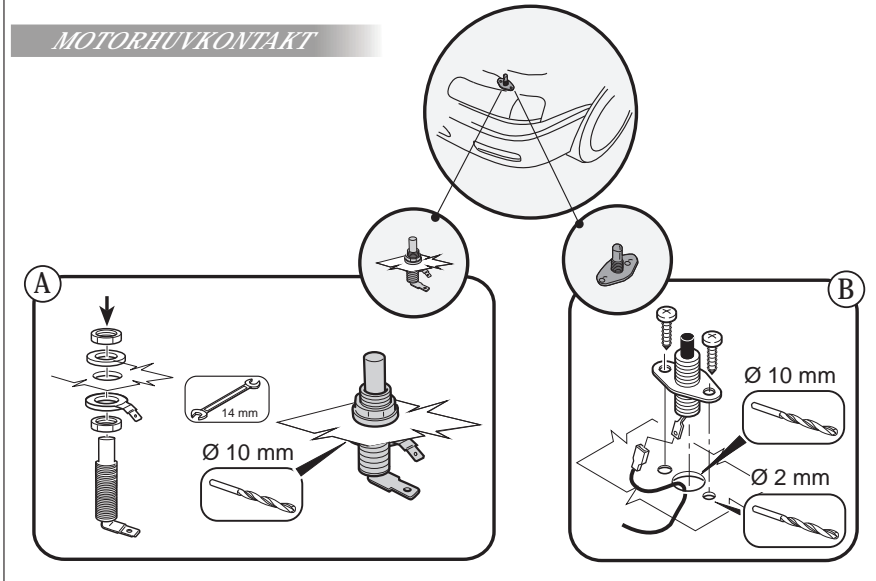

LED PANEL

