

---

Fitting instructions
Make: VW
Touareg; 2005->
Type: 4490

---

---

Permanently
linked to
quality

---

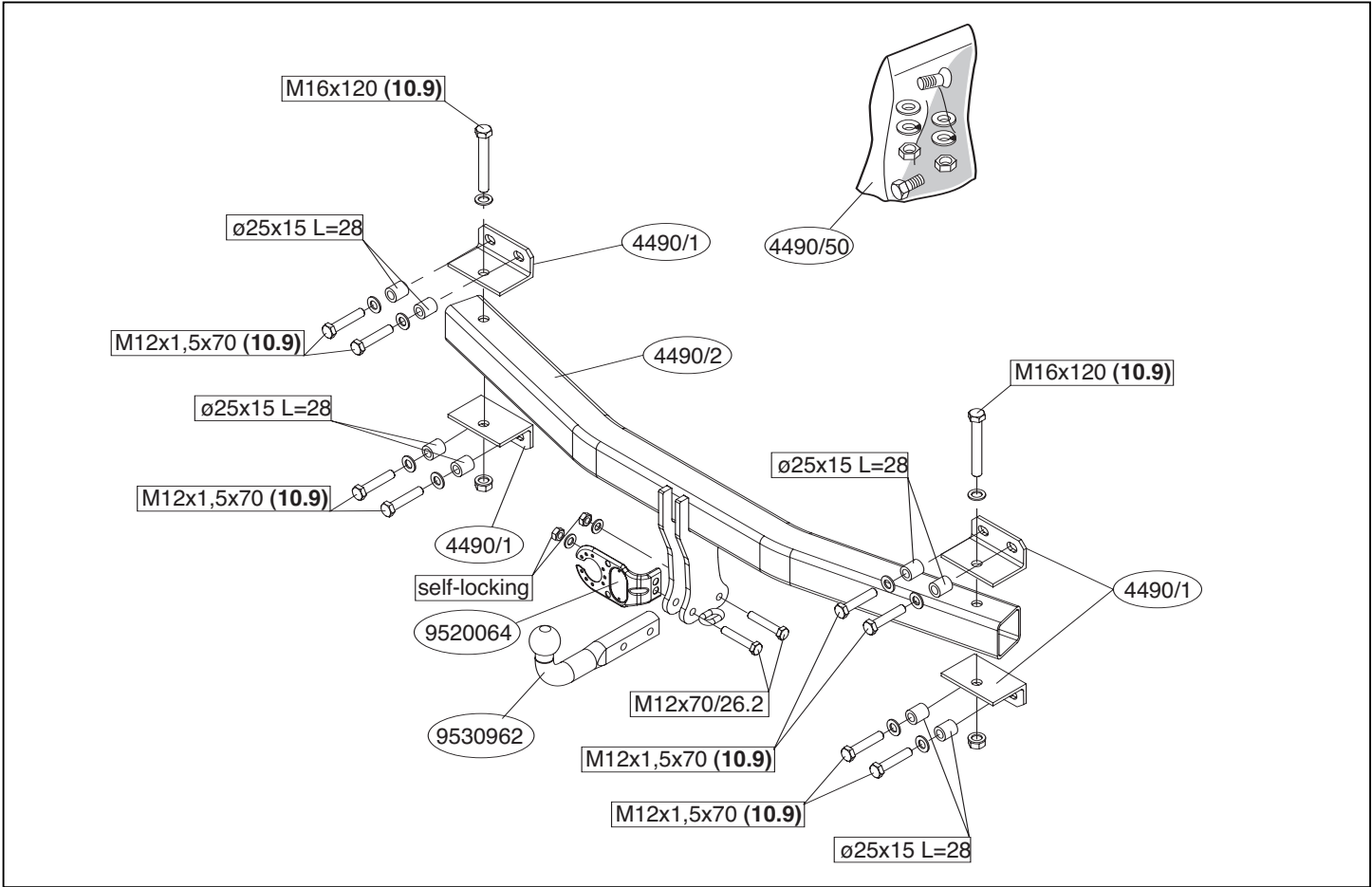

© 449070/10-12-2004/1

Dispositivo di traino tipo:  
Per autoveicoli:  
Tipo funzionale:

Brnk 4490  
VW Touareg; 2005->

Classe e tipo di attacco: A50-X  
Omologazione: e11 00-5284  
Valore D: 16,3 kN  
Carico Verticale max. S: 140 kg  
Larghezza rimorchiabile per Caravan e T.A.T.S.: 2,45m vedere CARTA di CIRCOLAZIONE VEICOLO (motrice) + 70 cm = ..arrotondare ai 5 cm superiore (vedi D.M.28/05/85)  
Massa rimorchiabile: vedi carta di circolazione dell' autoveicolo

Per verificare l'idoneità del dispositivo di traino omologato a norma CEE 94/20, all'installazione sulla vettura su cui si intende procedere al montaggio, compilare la seguente formula (se necessario) declassare la massa rimorchiabile):

$$D = \frac{T + C}{T \times C} \times 0,00981 = \dots \text{ kN} > D$$

dove: T= Massa Complessiva Max. della motrice (in kg)  
C= Massa Rimorchiabile Max. della motrice (in kg)

### DA COMPILARE PER IL COLLAUDO

**DICHIARAZIONE DI CORRETTO MONTAGGIO:** la sottoscritta Ditta dichiara di aver montato in maniera corretta ed in conformità alle prescrizioni sia del costruttore del veicolo che del costruttore del dispositivo stesso il seguente dispositivo di attacco meccanico:

**TIMBRO e FIRMA**

tipo:.....  
Il dispositivo di attacco sopra indicato è stato installato su autoveicolo

modello:.....

targa:.....

Data:.....

**Si dichiara inoltre di aver informato l'utente del veicolo sull'USO e MANUTENZIONE del dispositivo stesso.**



© 449070/10-12-2004/9

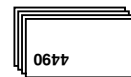
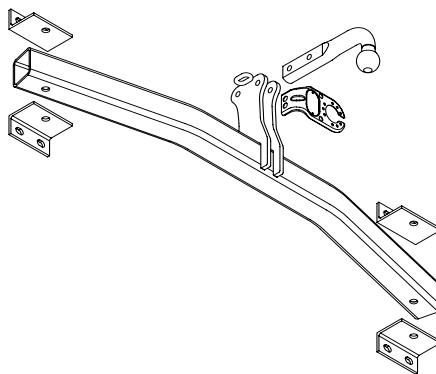
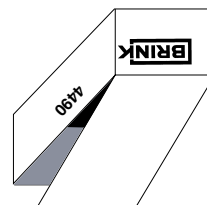

(2x) M12x70/26.2



(2x) M12 (self-locking)



(2x) M16 (self-locking flange-nut)

(8x) M12x1,5x70 (10.9)



(8x) ø25x15 L=28



(2x) M16x120 (10.9)

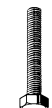

(10x) M12



(2x) M16



© 449070/10-12-2004/2

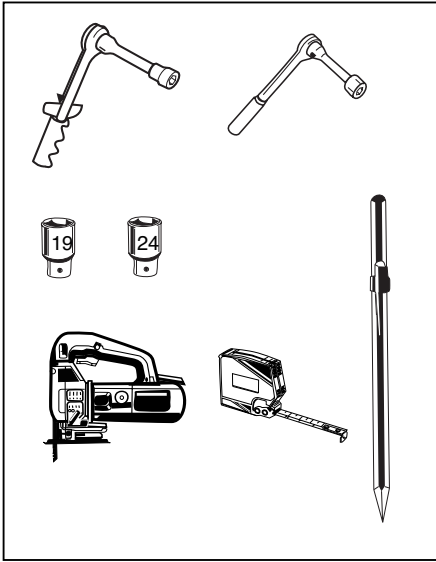

Couplingsclass: A50-X

euro tested

Approved

e11 00-5284

94/20/EC

D-value

$$D = \frac{K_{G \max} \times K_{G \max}}{K_{G \max} + K_{G \max}} \times \frac{9.81}{1000} = 16.3 \text{ kN}$$

8.8

10.9

!

8

10

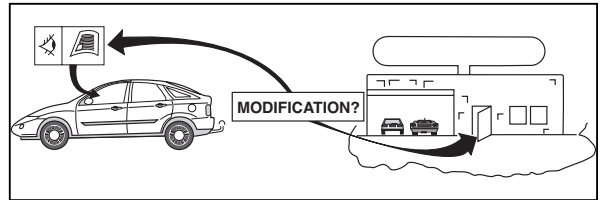
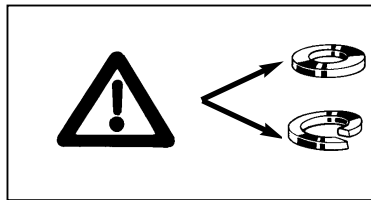
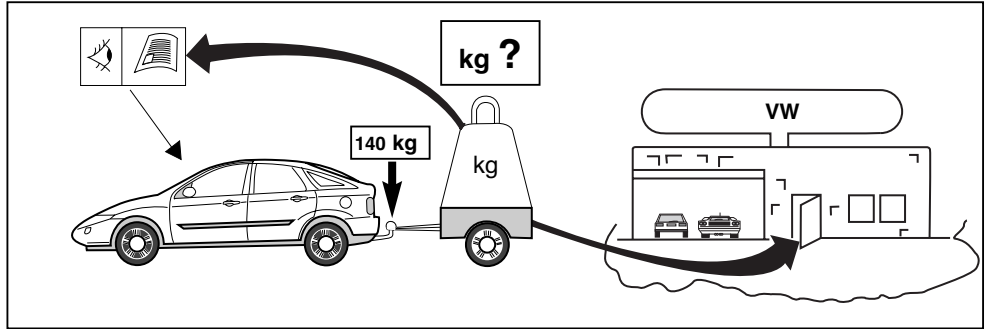

© 449070/10-12-2004/3

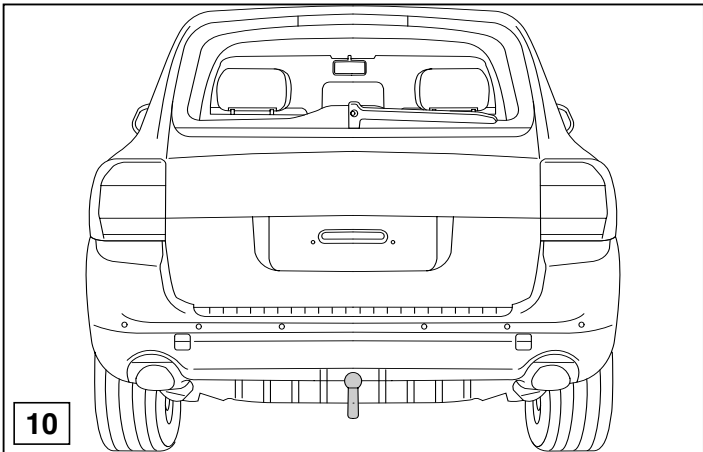

© 449070/10-12-2004/8



1000km

+



0km

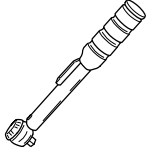

---





**M16**  
250 Nm

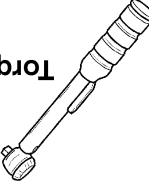

**M12x1,5**  
122Nm

**Torque settings for nuts and bolts (10.9)**





**M12**  
71Nm (with self-locking nut)

**Torque settings for nuts and bolts (8.8)**

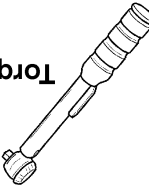

**HINWEISE:**

\* Die für das Fahrzeug zugelassene Anhängelast ist den Fahrzeug Unterlagen zu entnehmen. Bei Änderungen des Fahrzeuggewichtes muß die höchstzulässige Anhängelast gegebenenfalls aus dem D-Wert nachgerechnet werden.

\* Auskunft hierüber kann Ihr Fachhändler oder der TÜV geben.

\* Elektrische Anlage gemäß SIVZO anbringen.

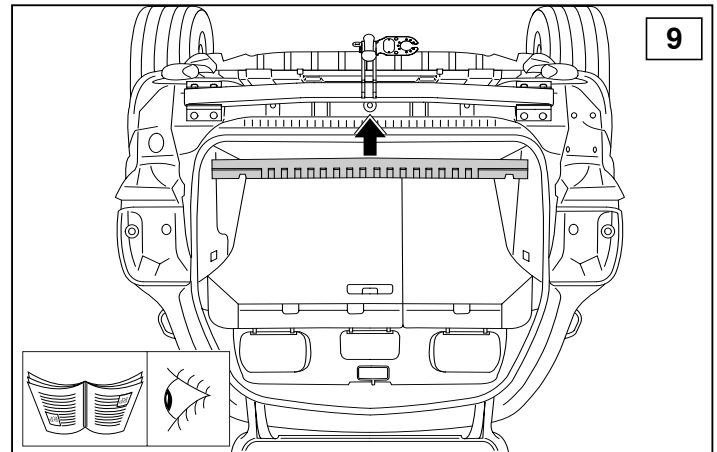
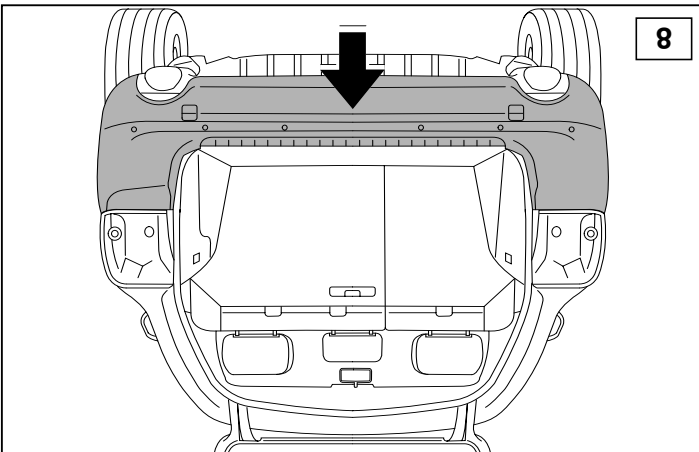
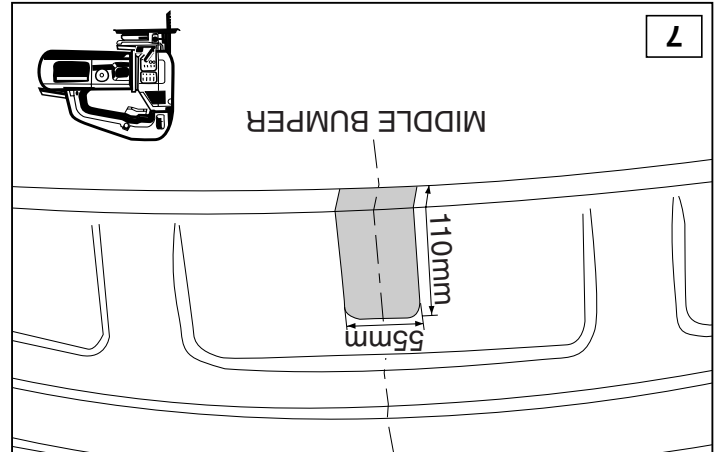
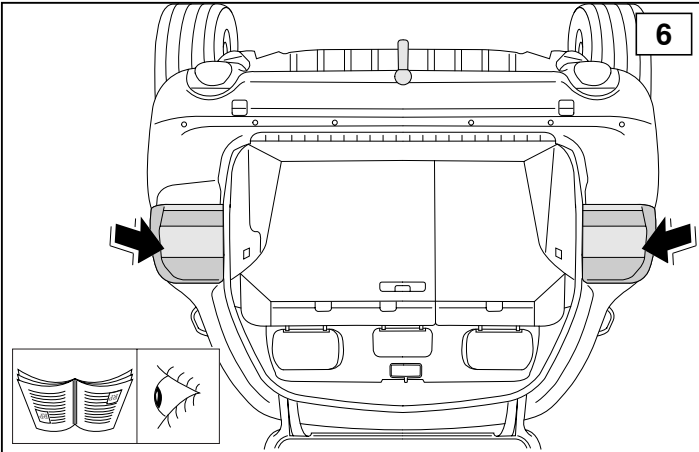

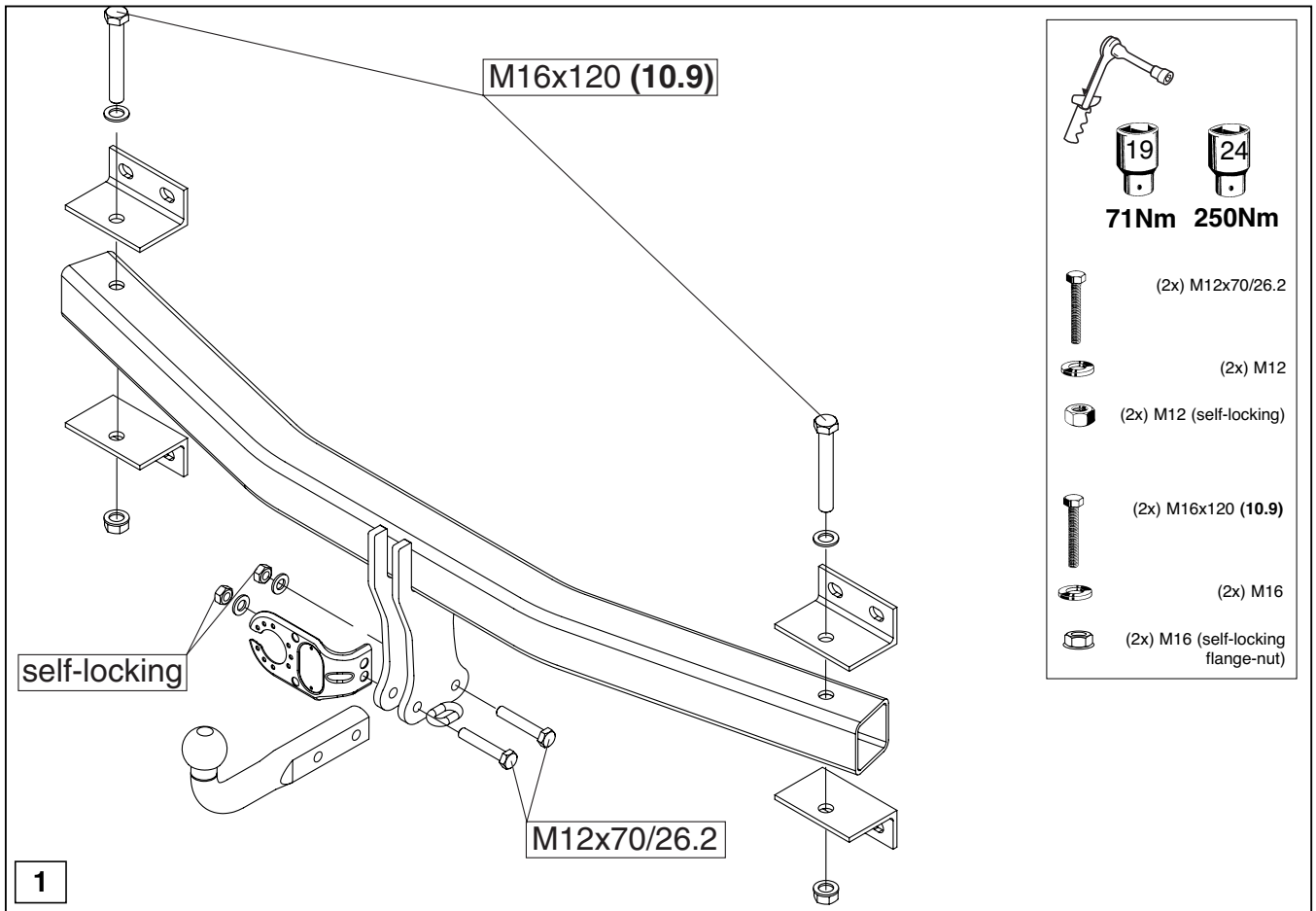

© 449070/10-12-2004/5

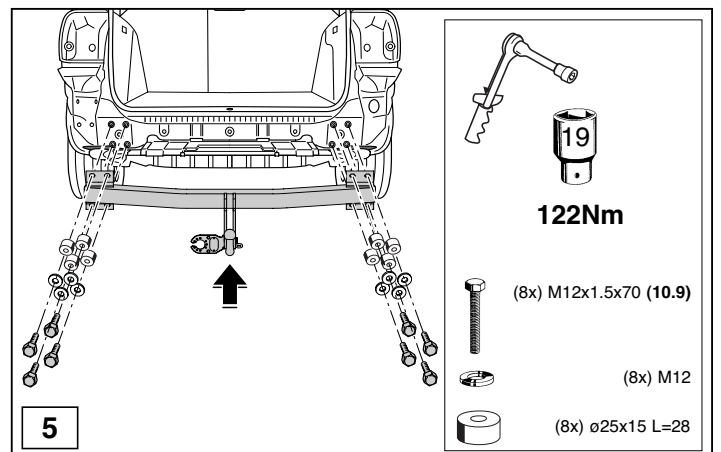
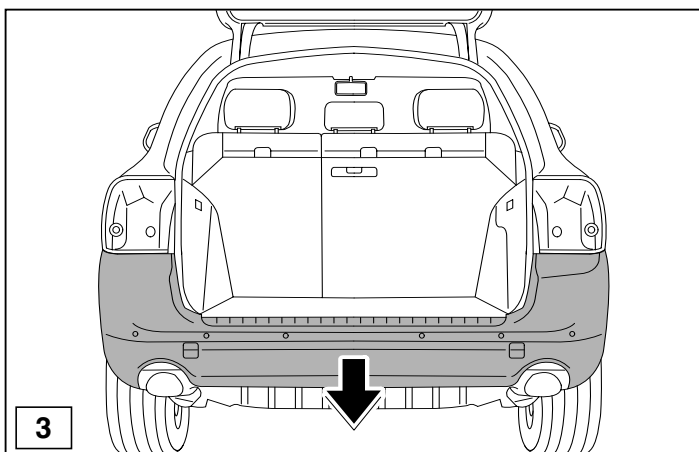
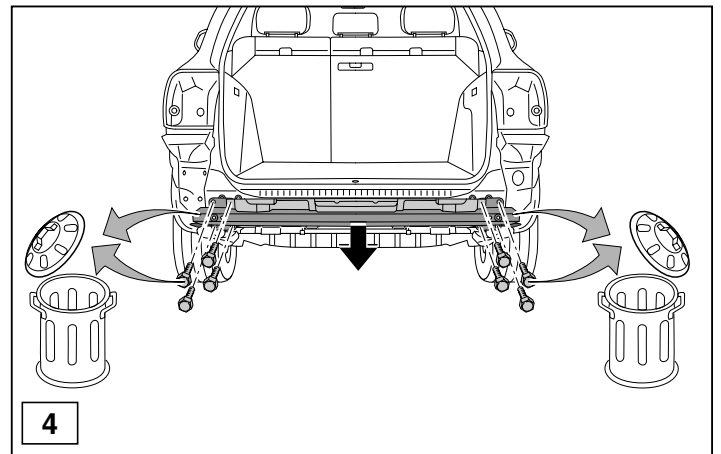
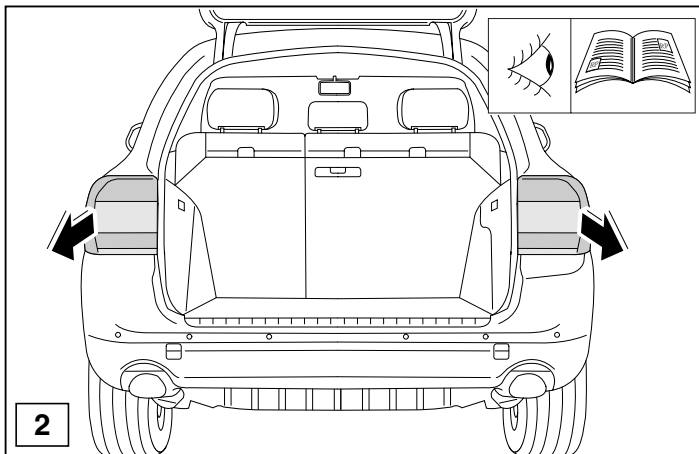

© 449070/10-12-2004/6