

Fitting instructions

Make: Citroën

C5

Type: 4821

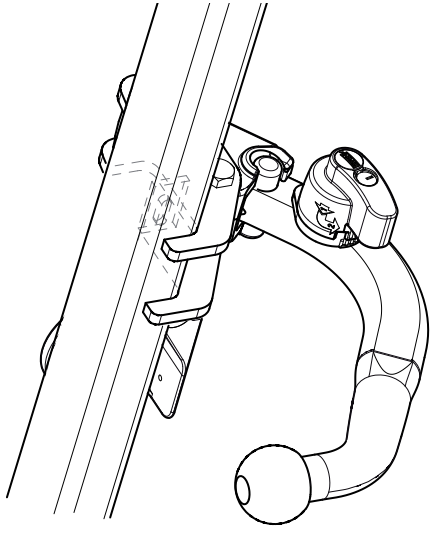

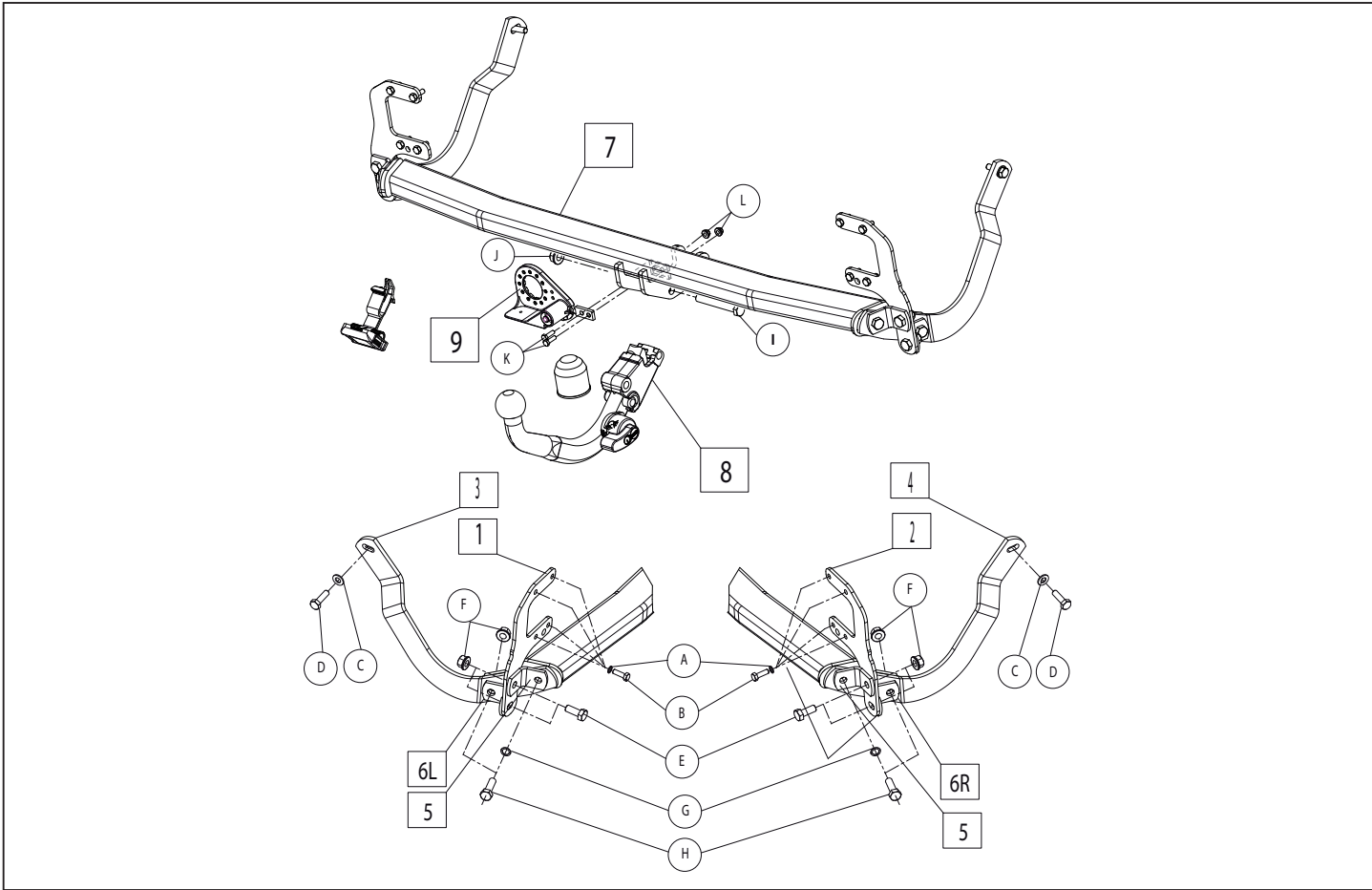

© 482170/17-06-2009/1

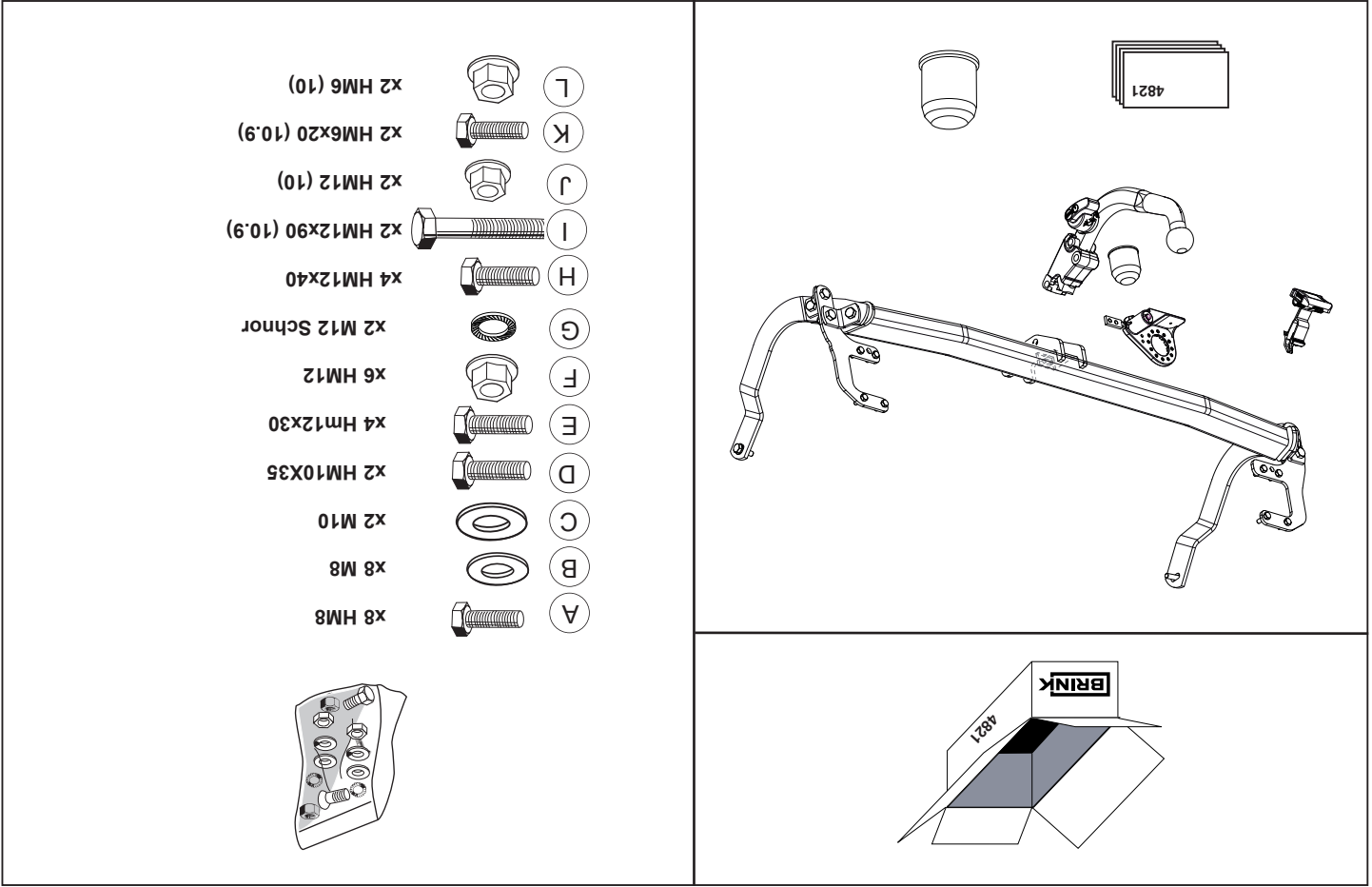

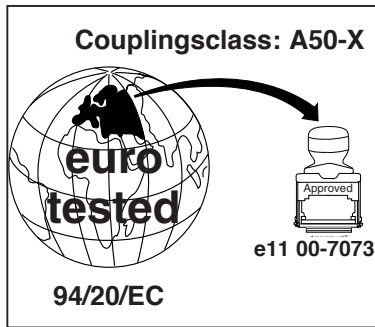
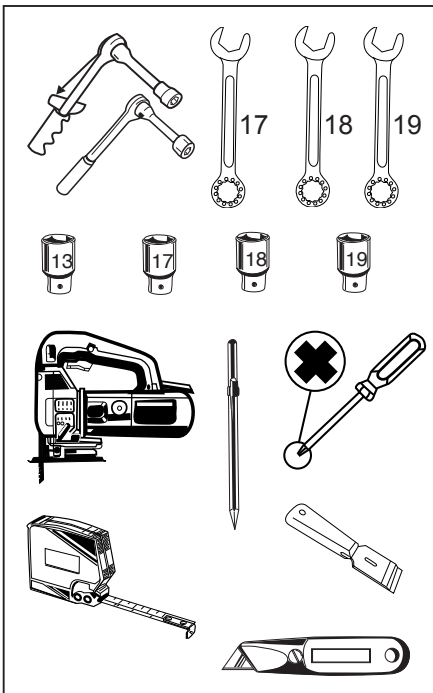

D-Value :10,31 kN

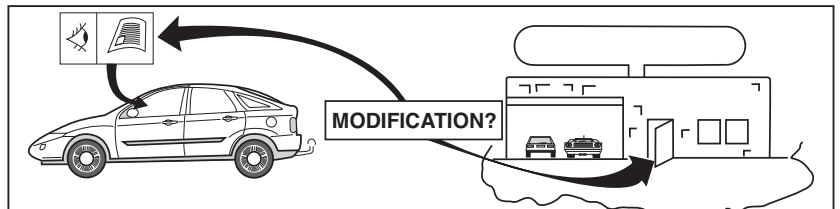
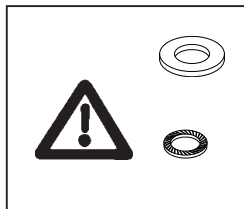
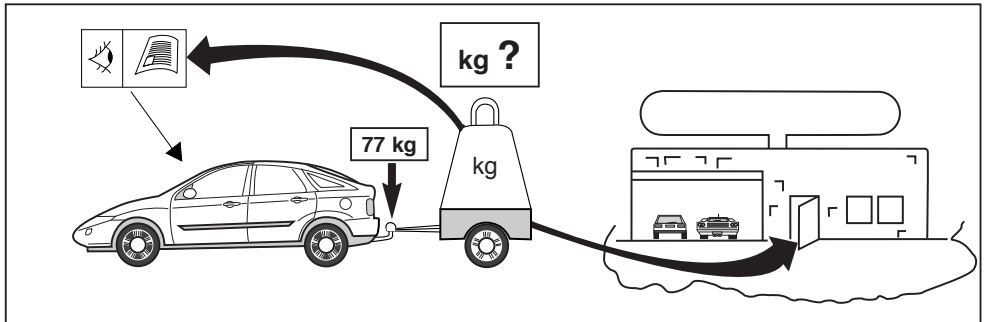

© 482170/17-06-2009/3

Dispositivo di traino tipo: 4821

Per autoveicoli: Citroën C5

Tipo funzionale: RW****

Classe e tipo di attacco: A50-X

Omologazione: e11 00-7073

Valore D: 10,31 kN

Carico Verticale max. S: 77 kg kg

Larghezza rimorchiabile per Caravan e T.A.T.S.: 2,55m vedere CARTA di CIRCOLAZIONE VEICOLO (motrice) + 70 cm = ..arrotondare ai 5 cm superiore (vedi D.M.28/05/85)

Massa rimorchiabile: vedi carta di circolazione dell' autoveicolo



Per verificare l' idoneità del dispositivo di traino omologato a norma CEE 94/20, all' installazione sulla vettura su cui si intende procedere al montaggio, compilare la seguente formula (se necessario declassare la massa rimorchiabile):

$$D = \frac{T \times C}{T + C} \times 0,00981 \leq 10,31 \text{ kN}$$

dove: T= Massa Complessiva Max. della motrice (in kg)
C= Massa Rimorchiabile Max. della motrice (in kg)

DA COMPILARE PER IL COLLAUDO

DICHIARAZIONE DI CORRETTO MONTAGGIO: la sottoscritta Ditta dichiara di aver montato in maniera corretta ed in conformi/ alle prescrizioni sia del costruttore del veicolo che del costruttore del dispositivo stesso il seguente dispositivo di attacco meccanico:

tipo:.....
Il dispositivo di attacco sopra indicato è stato installato su autoveicolo
modello:.....
targa:.....
Data:.....

TIMBRO e FIRMA

Si dichiara inoltre di aver informato l'utente del veicolo sull'USO e MANUTENZIONE del dispositivo stesso.

© 482170/17-06-2009/16

* Die für das Fahrzeug zugelassene Anhängelast ist den Fahrzeug Unterlagen zu entnehmen. Bei Änderungen des Fahrzeuggewichtes mu die höchstzulässige Anhängelast gegebenenfalls aus dem D-Wert nachgerechnet werden.
* Elektrische Anlage gemäß SIVZO anbringen.
Auskunft hierüber kann Ihr Fachhändler oder der TÜV geben.

HINWEISE:

All measurements are in mm!

* Should this installation process entail the cutting of the bumper – conformation **MUST** be obtained by the installation engineer or the customer's acceptance prior to completion. Thule Towing Systems do not accept responsibility for any matters arising as a result of this miscommunication.

NOTE:

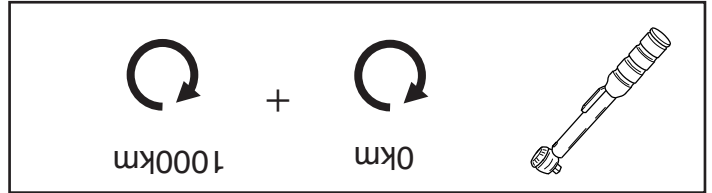

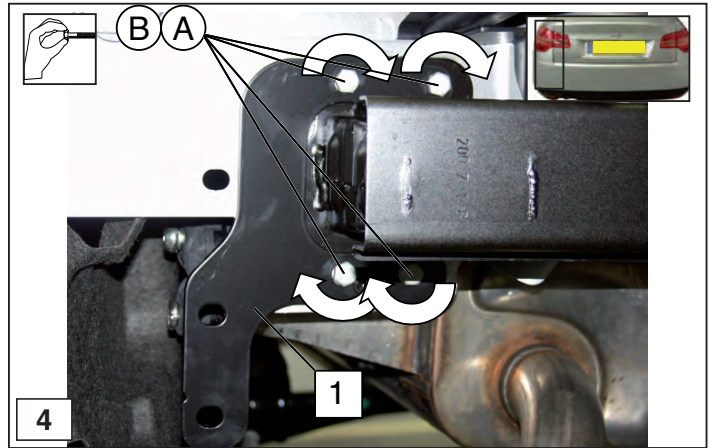
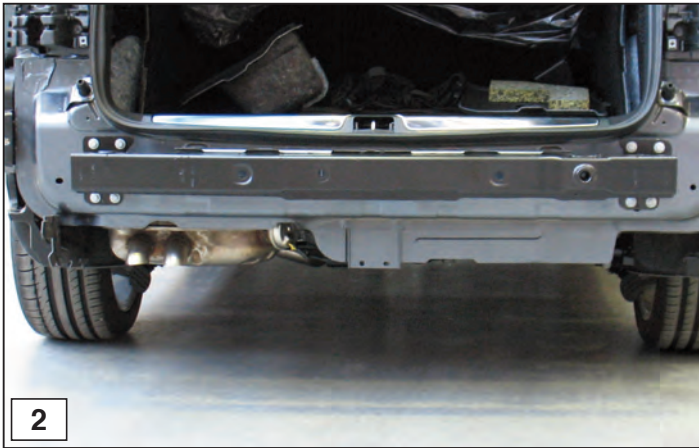
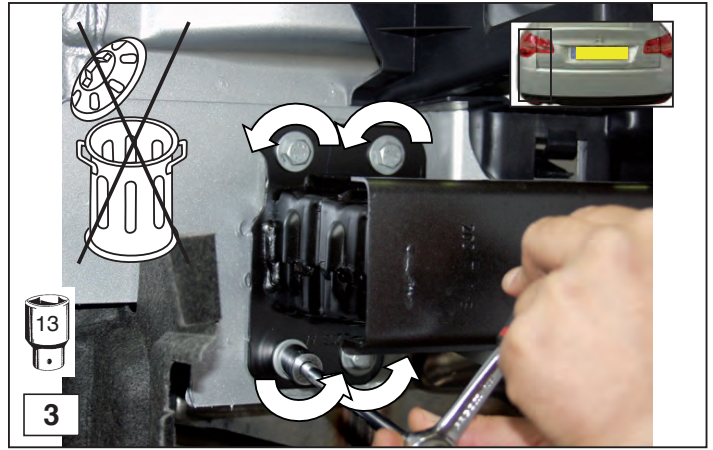

© 482170/17-06-2009/5

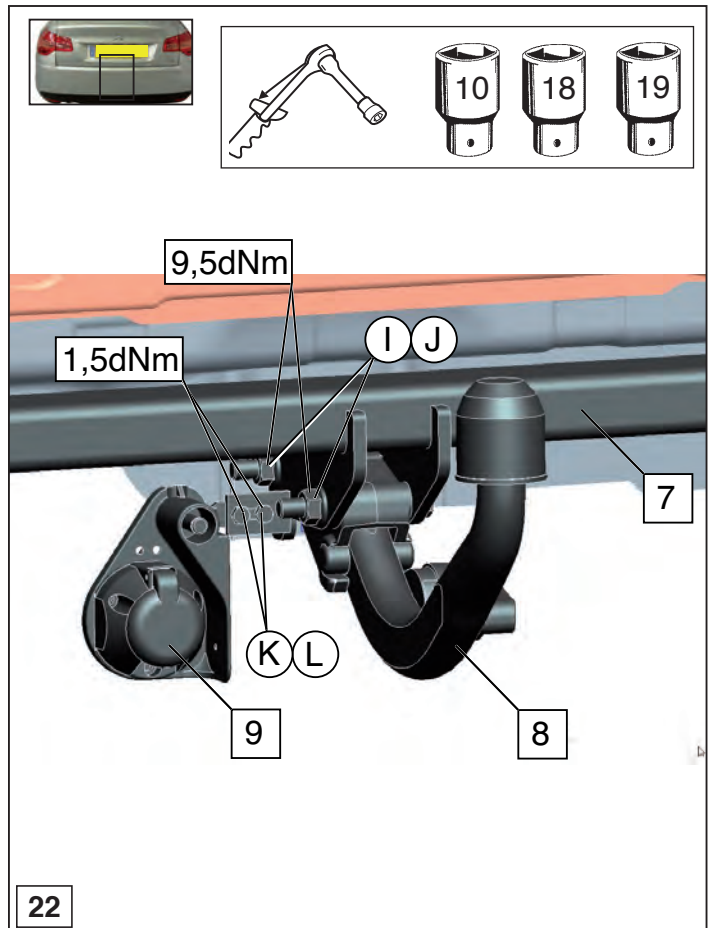
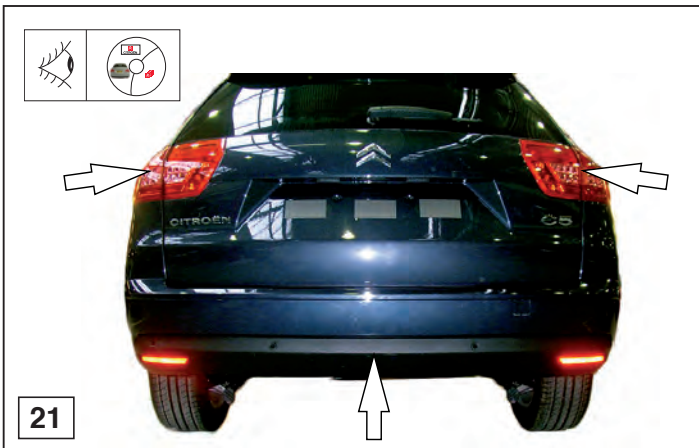

© 482170/17-06-2009/14

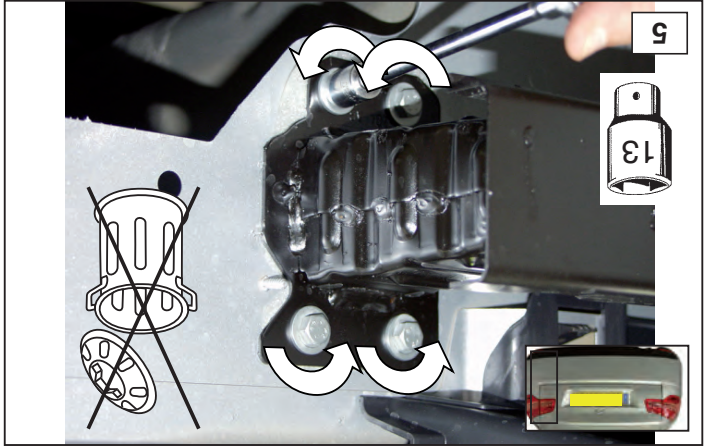
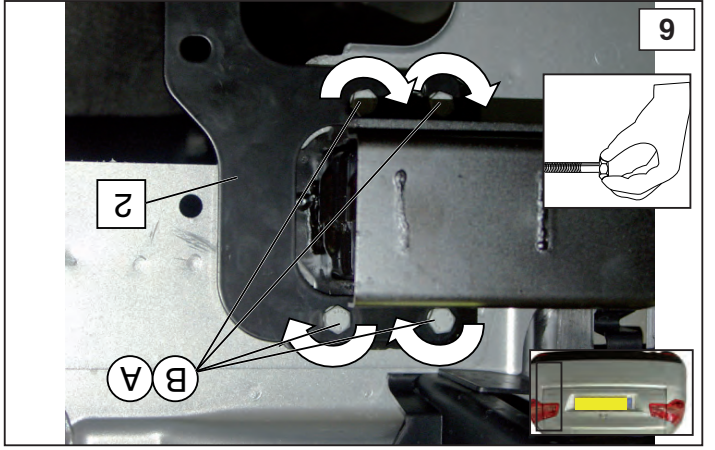

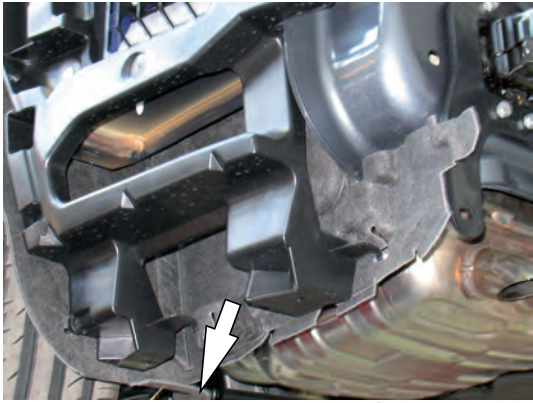

7

© 482170/17-06-2009/7

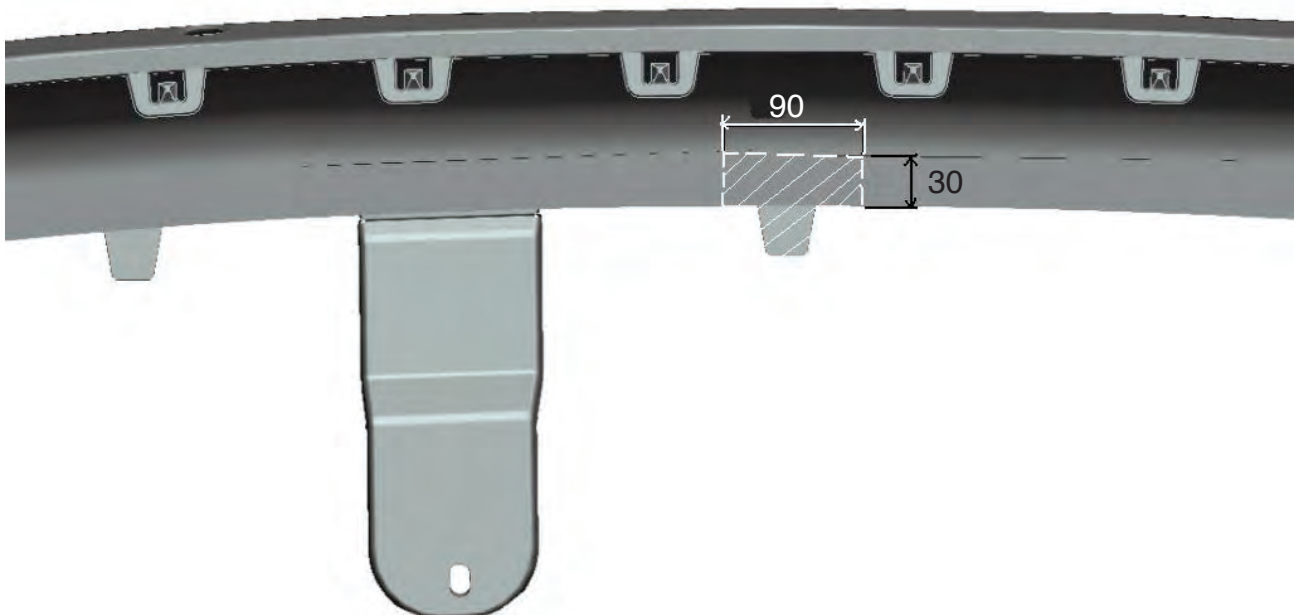
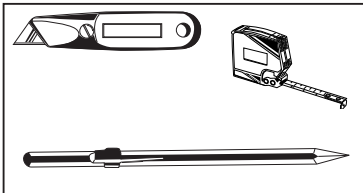

18

© 482170/17-06-2009/12

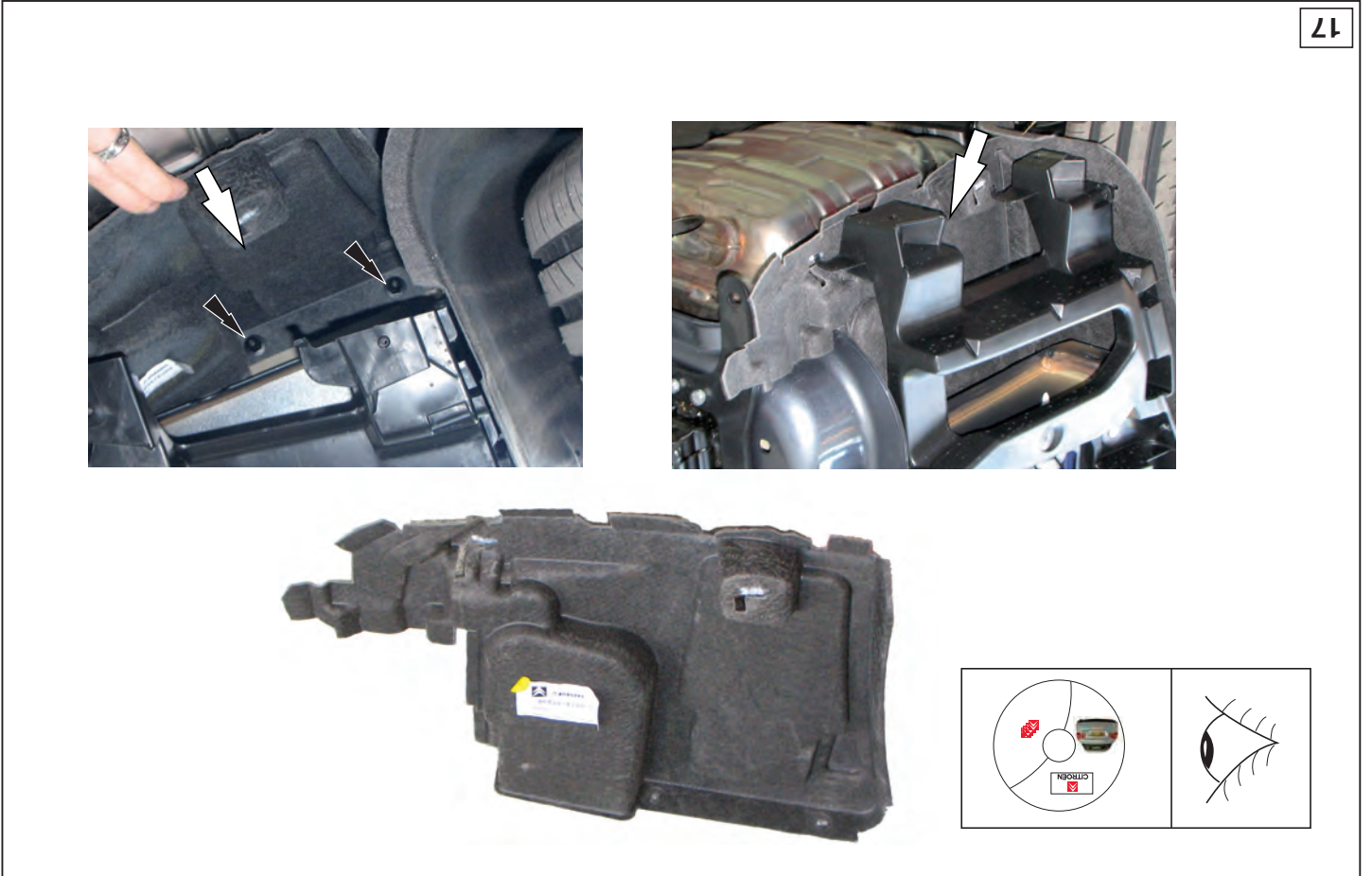
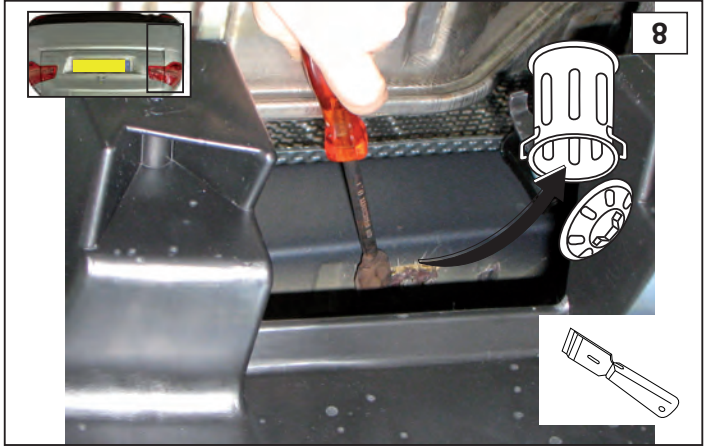
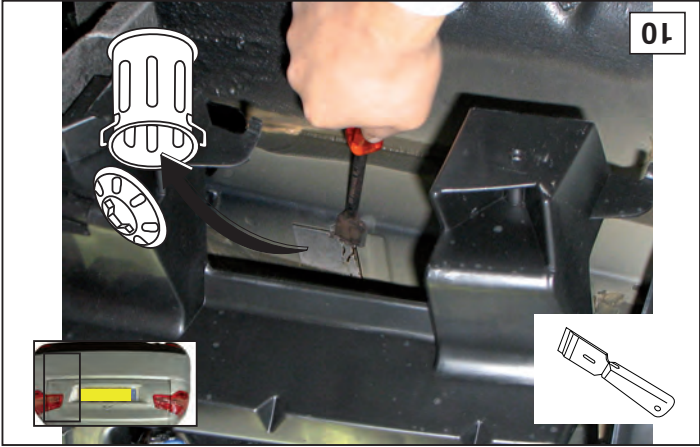
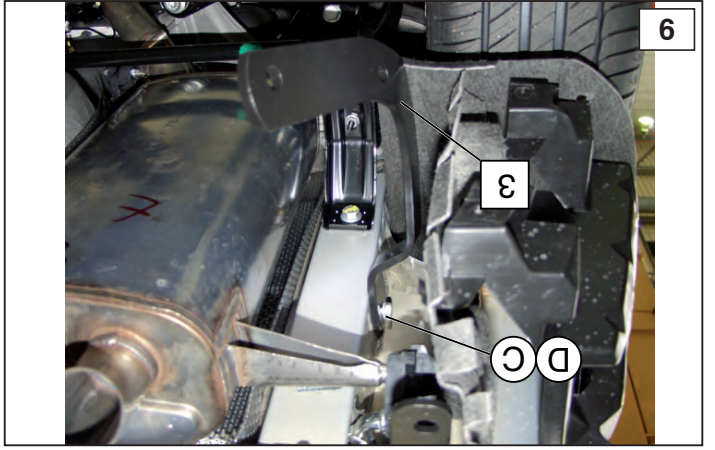
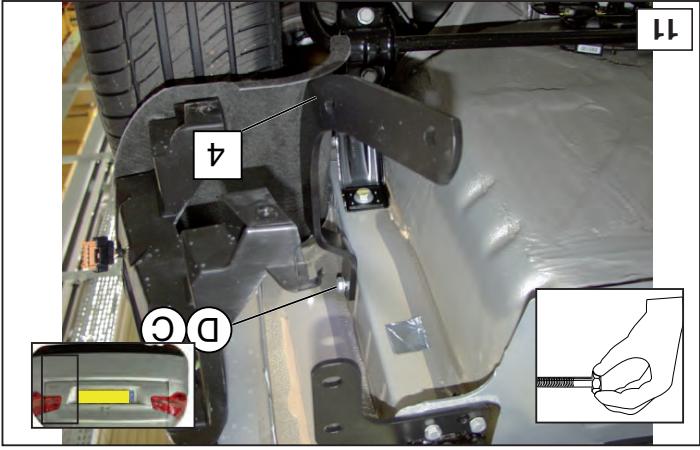

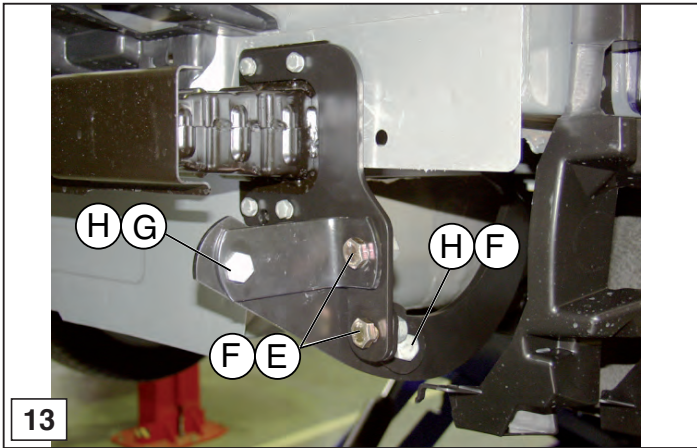
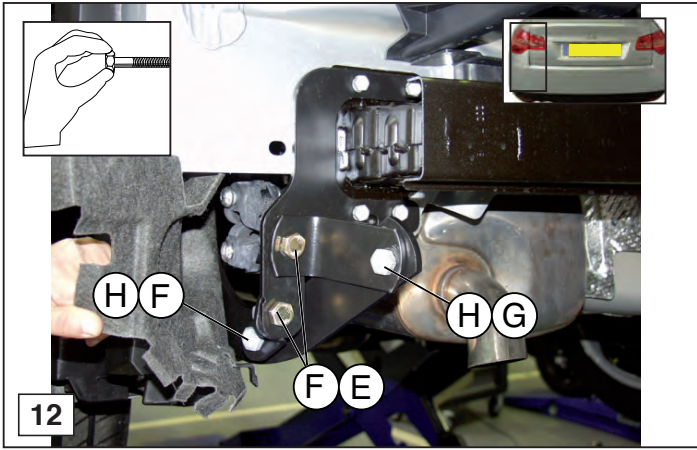

© 482170/17-06-2009/9

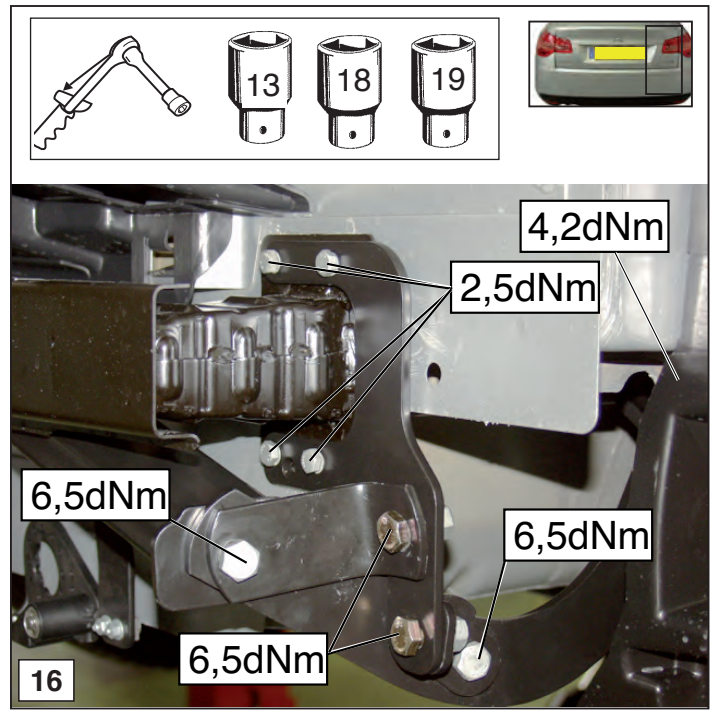
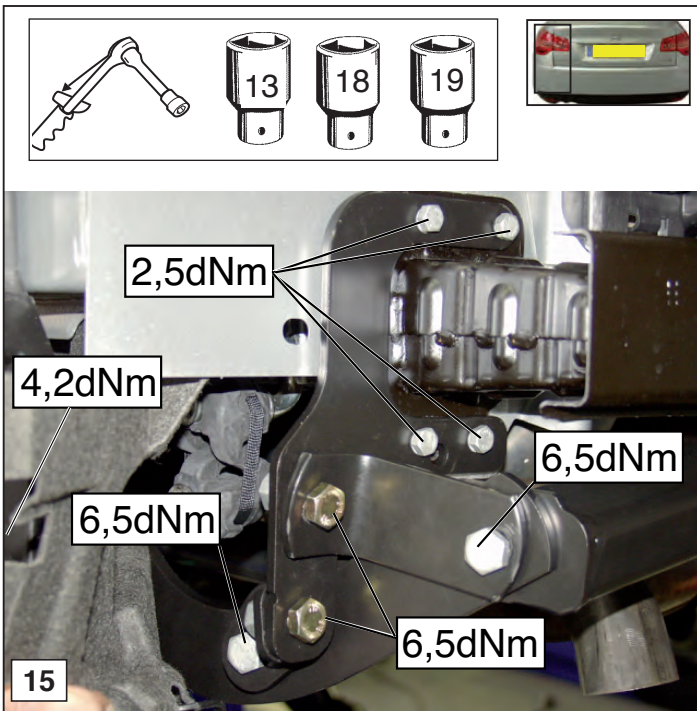

© 482170/17-06-2009/10