

304 151 600 001 / 304 152 600 001

ATTENTION : (pour connaître les caractéristiques d'utilisation consulter la carte grise).

Installé suivant nos recommandations, cet attelage vous donnera entière satisfaction. Nous dégageons toute responsabilité en cas de transformation ou d'utilisation illicite de celui-ci

FR

DE

ACHTUNG: (Nutzungsmerkmale : siehe Fahrzeugschein)

Diese Anlageneinrichtung wird Sie voll zufrieden stellen, wenn Sie unsere Montageanleitung befolgen.
Im Falle der unerlaubten Veränderung oder des unerlaubten Gebrauchs lehnen wir jede Haftung ab.

DA

BEMÆRK : (for yderligere oplysninger om anvendelsesforhold henvises der til registreringsattesten)

Hvis dette anhangstræk monteres i henhold til vores anvisninger, vil det være til din fulde tilfredshed. Vi fralægger os ethvert ansvar ved ulovlig ændring eller brug af anhangstrækket.

ES

ATENCIÓN: (para conocer las características de utilización, consultar el permiso de circulación)

Instalado siguiendo nuestras recomendaciones, este enganche le dará total satisfacción. No asumiremos ninguna responsabilidad en caso de que haya sido transformado o utilizado ilícitamente.

FI

HUOMIO: (käyttöomaisuuskin turustumiseksi on katsottava rekisteriotetta)

Suosittelun mukaan asennettuna tämä vetokoukku täyttää odotuksesi.
Ennen ota vastuuta, jos laitetta muutetaan tai käytetään ohjeiden vastaisesti.

NL

LET OP : (voor gebruikskenmerken het kentekenbewijs raadplegen)

Indien u de koppeling volgens onze aanbevelingen heeft geïnstalleerd, zal het u tot volle tevredenheid stemmen. Wij stellen ons niet aansprakelijk in geval van wijziging of onrechtmatig gebruik.

CZ

POZOR: (užívateľské charakteristiky naleznete v technickém průkazu)

Tažné zařízení instalované dle našich doporučení vás plně uspokojí. V případě přestavby nebo neoprávněného užívání se zbavujeme veškeré odpovědnosti

EN

PLEASE NOTE : (to familiarise yourself with the operating characteristics refer to the log).

If this tow bar is fitted in accordance with our recommendations it will give a completely satisfactory result. We cannot accept any responsibility in the event of changes to or improper use of this item.

EL

ΠΡΟΣΟΧΗ : (για να π.ηπορορηθετε τα χαρακτηριστικα χρησιης συμβου.υ.ευρετε την ηκρητα κάρτα)

Εγκατεστημένο σύμφωνα με τις συστάσεις μας, αυτό το σύστημα συνολικά θα σας ικανοποιήσει πλήρως. Ανεξαρτησία δράσης ευθύνης σε περίπτωση μετατροπής ή παράνομης χρήσης αυτού.

PL

UWAGA (charakterystyki użytkowania należy sprawdzić w dowodzie rejestracyjnym)

Dzyszel holowniczy będzie funkcjonował we właściwy sposób po zamontowaniu go zgodnie z zaleceniami. Nie ponosimy żadnej odpowiedzialności w przypadku wprowadzenia zmian lub nieuzwolnionego użycia

IT

ATTENZIONE : (per conoscere le caratteristiche d'uso consultare il libretto di circolazione)

Installato seguendo le nostre raccomandazioni, questo gancio da traino vi lascerà completamente soddisfatti. Respungiamo ogni responsabilità in caso di trasformazione o utilizzo illecito dello stesso.

NO

ADVARSEL: (for kunnskap om brukssegenskapene, se vognkortet)

Ved å installere innretningen i samsvar med våre anbefalinger vil du få maksimalt utbytte av dette tilhengerfestet. Vi fraskriver oss alt ansvar hvis tilhengerfestet endres eller brukes på ulovlig måte.

SV

VARNING: (Läs igenom registreringsbeviset för att ta reda på rådande användningsvillkor)

Om du monterar produkten enligt våra anvisningar kommer du uppnå bästa möjliga resultat. Vi avstår oss allt ansvar i de fall kunden inte följer våra anvisningar fullt ut.



siarr
WESTFALIA AUTOMOTIVE

304151600001 (SI219)
304152600001 (SI220)

PEUGEOT 308



2170 kg

PEUGEOT 308 SW



CITROËN C4 Picasso



**CITROËN C4
Grand Picasso**



1750 kg



9,5 kN



75 kg

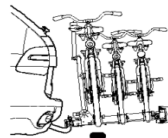

3 MAXI
60 Kg MAXI



30 Kg MAXI

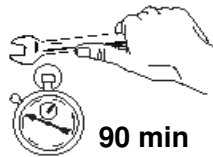

90 min

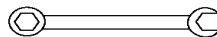
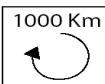
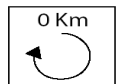

SI 219
e24*55R*01*0347*00
SI 220
e24*55R*01*0348*00

304151



21 kg

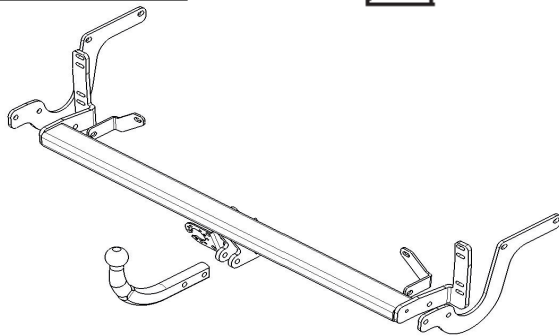

304152



24 kg

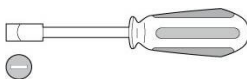
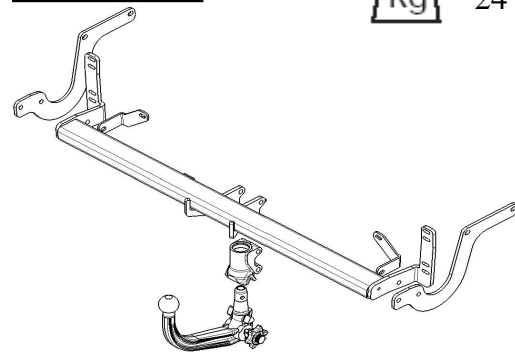

13 - 16 - 17 - 18 - 19



T20
T30

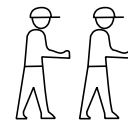
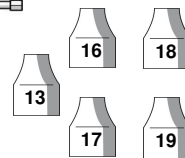
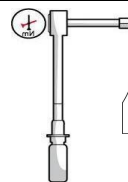

6

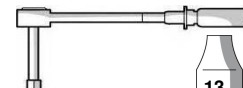

304151/304152









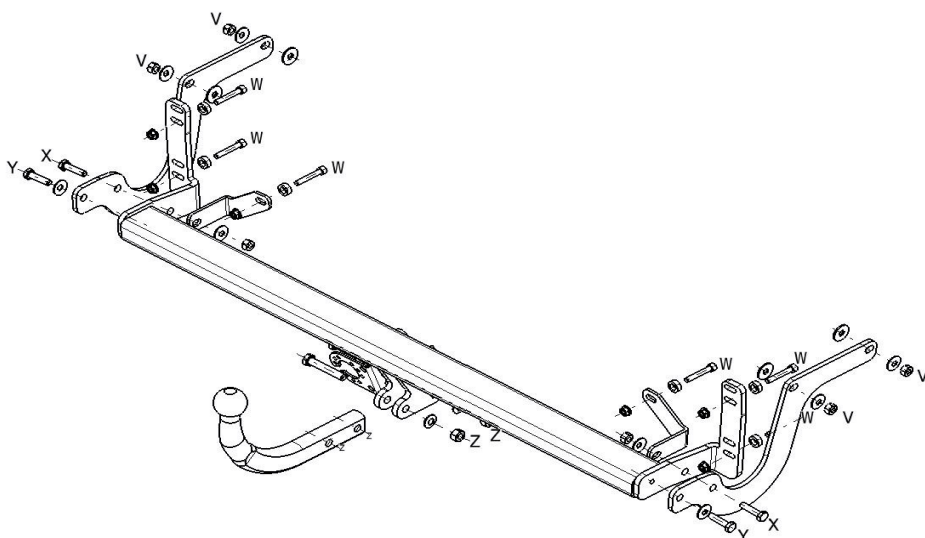





Indice B

11/08/2014

1/14

304151



VISSERIE		QTÉ
V	 Ø10,5/Ø27x2	x4
	 CS Ø10x27	x4
	 M10 - cl8 - 47Nm	x4
W	 Entretoise	x6
	 CHC M8x50 - cl12,9 - 25Nm	x6
	 M8 - cl10	x6
X	 HM10x40 - cl8.8 - 47 Nm	x2
	 CS Ø10x27	x2
	 M10 - cl8	x2
Y	 HM10x40 - cl8.8 - 47 Nm	x2
	 CS Ø10x27	x2
Z	 HM12x70 - cl8.8 - 81 Nm	x4
	 Ø13x27	x4
	 CS Ø12x24	x4
	 M12 - Cl8	x4

304151/304152









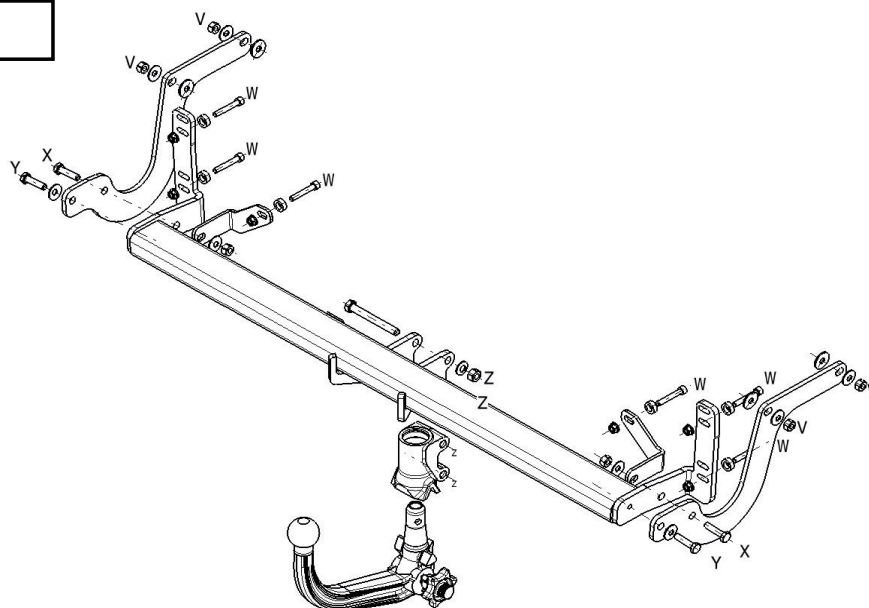





Indice B

11/08/2014

2/14

304152



VISSERIE		QTÉ
V	 Ø10,5/Ø27x2	x4
	 CS Ø10x27	x4
	 M10 - c18 - 47Nm	x4
W	 Entretoise	x6
	 CHC M8x50 - c12,9 - 25Nm	x6
	 M8 - c10	x6
X	 HM10x40 - c18.8 - 47 Nm	x2
	 CS Ø10x27	x2
	 M10 - c18	x2
Y	 HM10x40 - c18.8 - 47 Nm	x2
	 CS Ø10x27	x2
Z	 HM12x100 - c10.9 - 114 Nm	x3
	 CS Ø12x24	x3
	 M12 - C110	x3

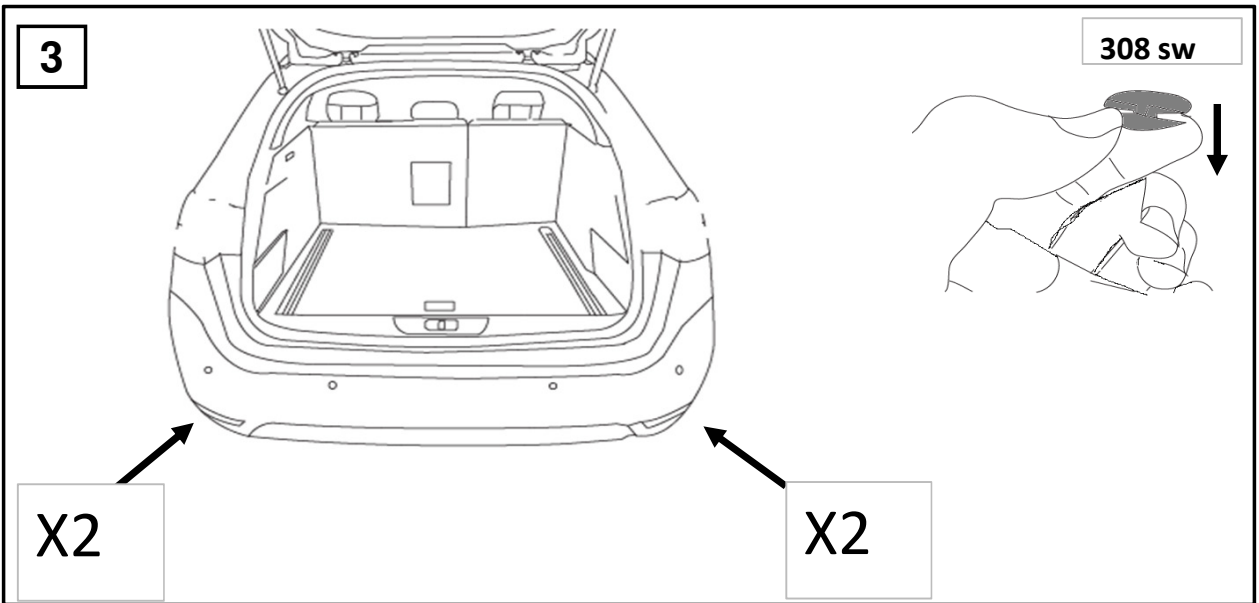
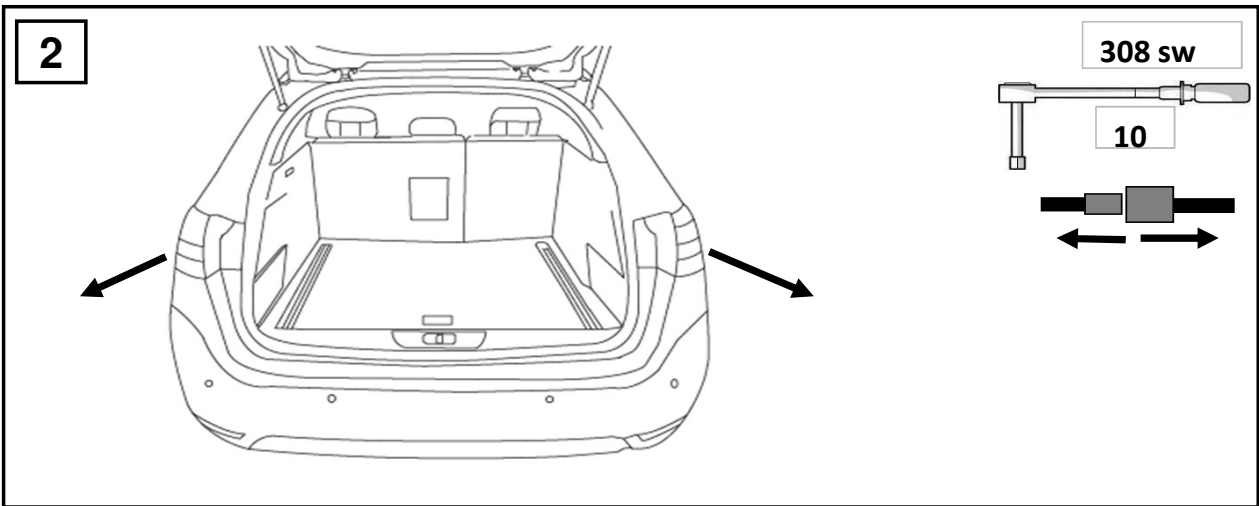
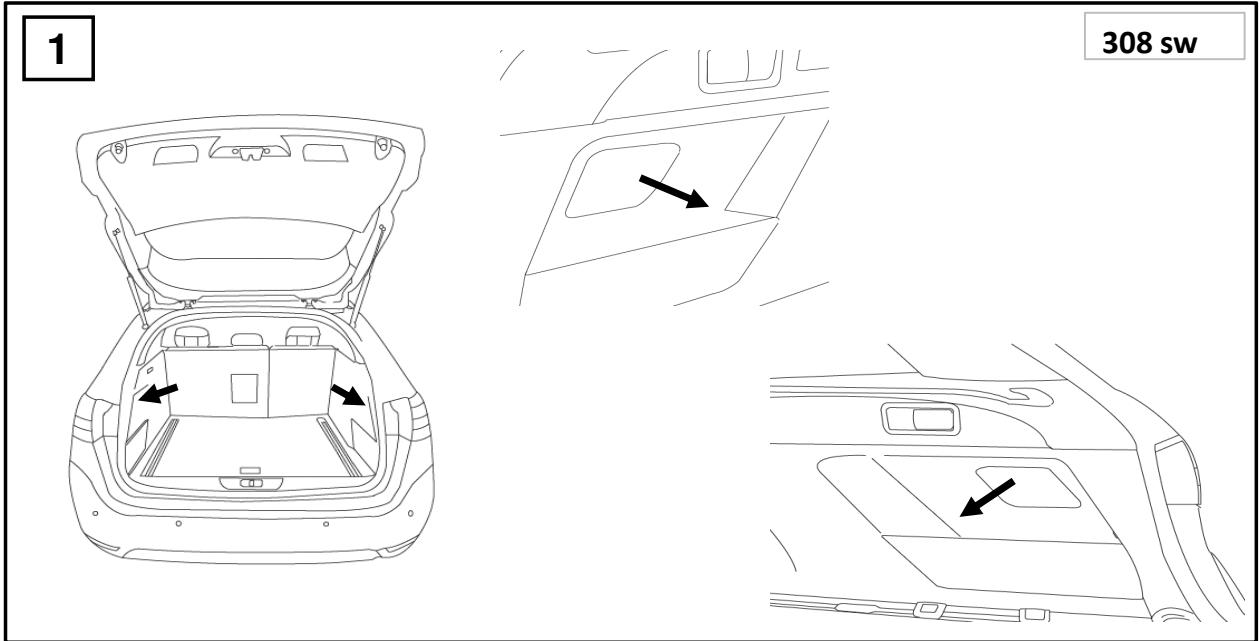

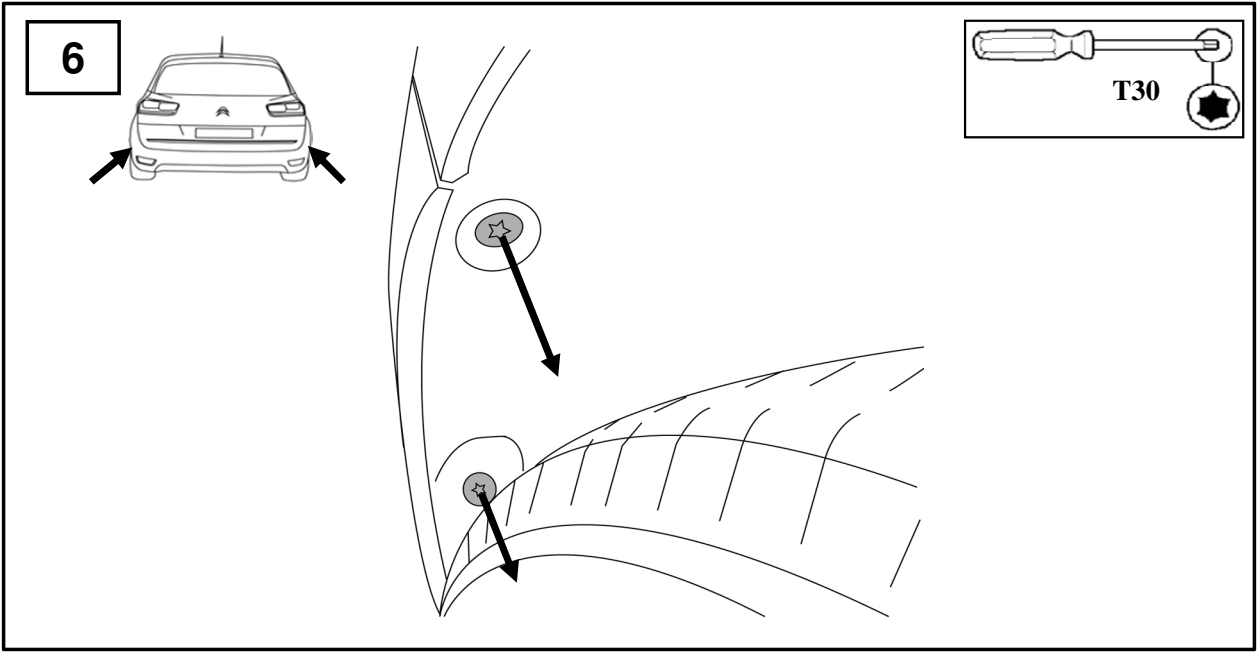
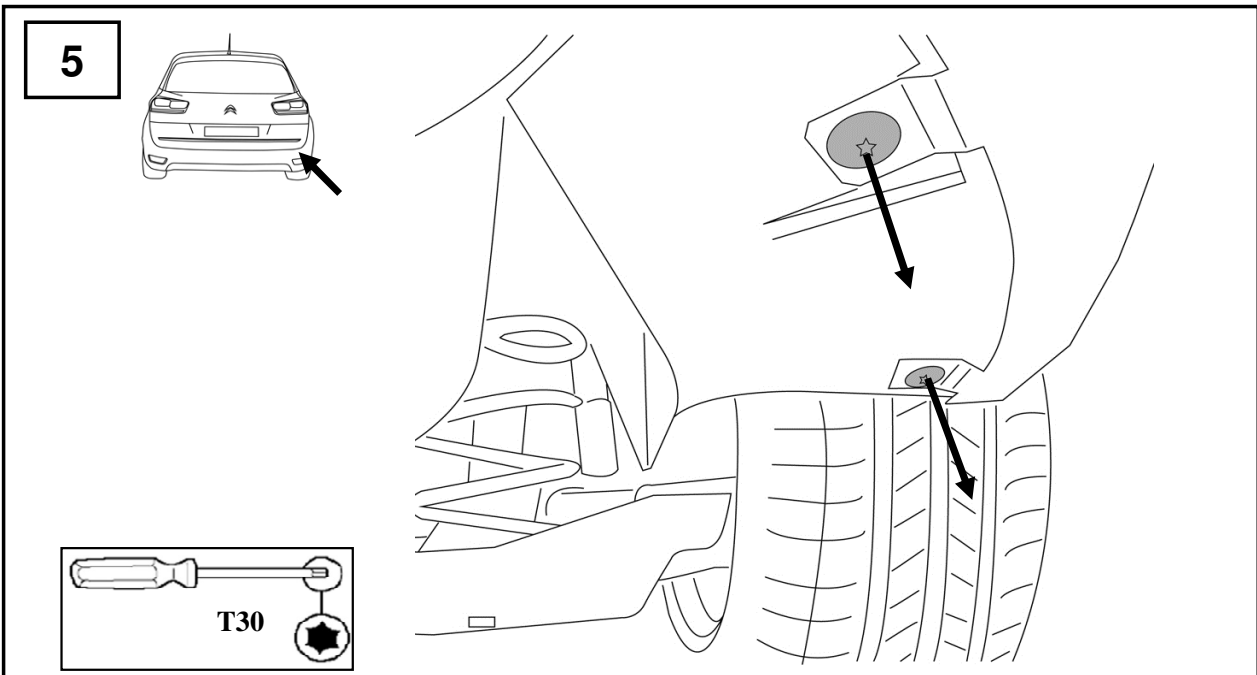
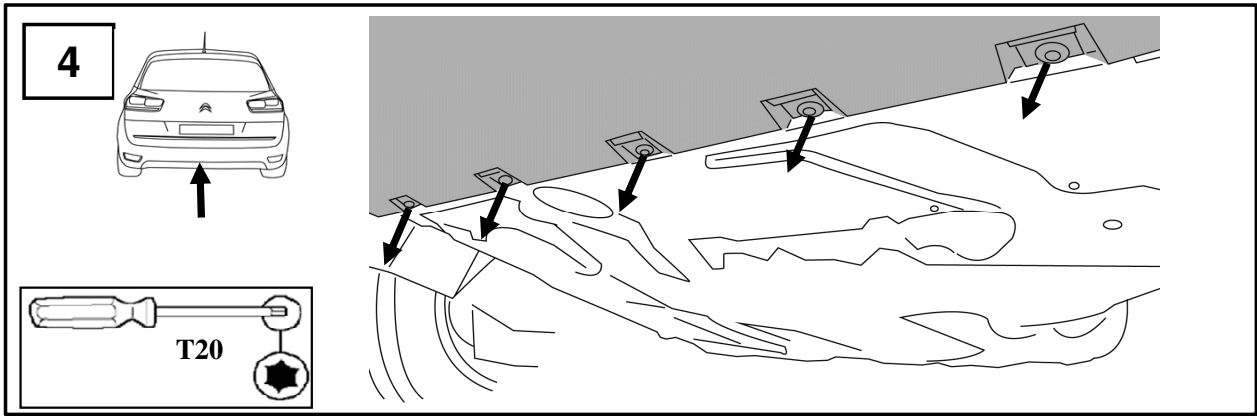

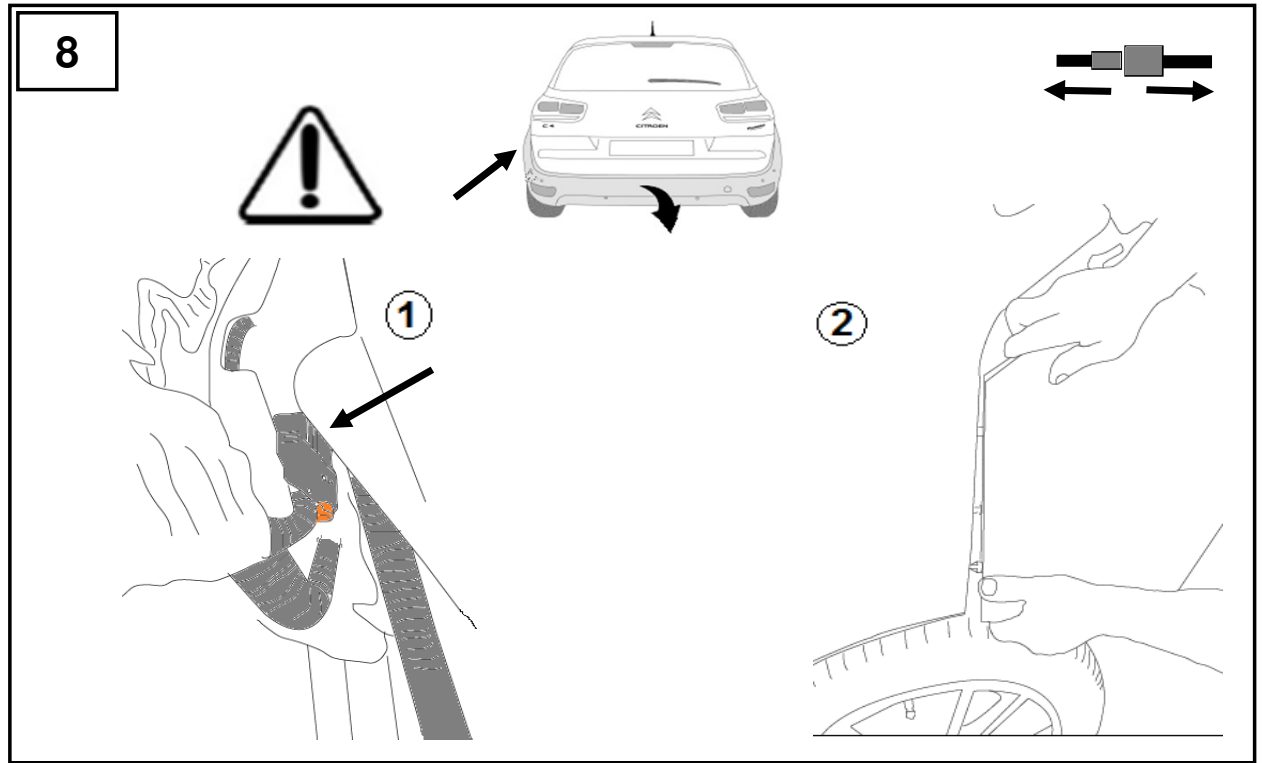
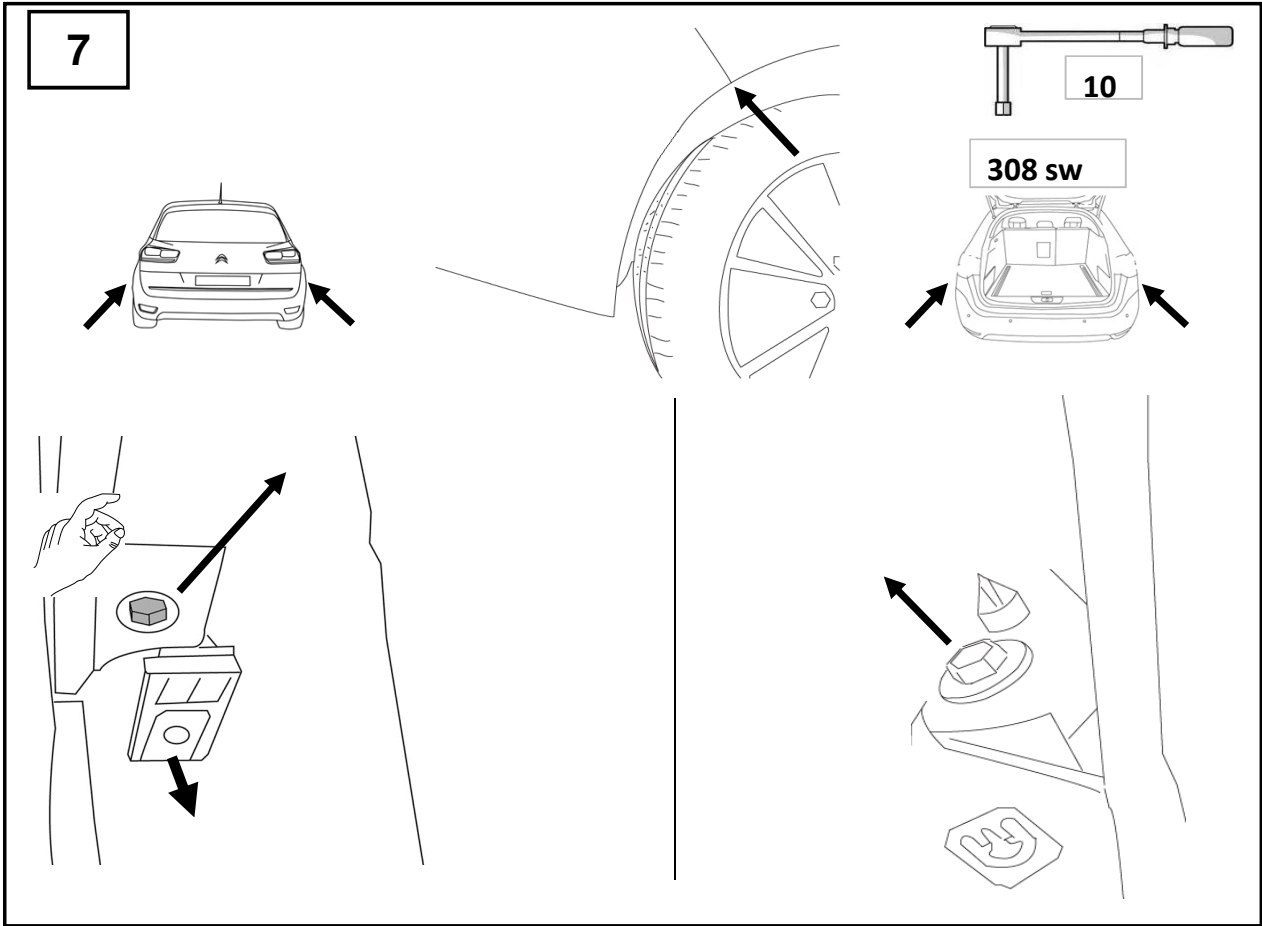

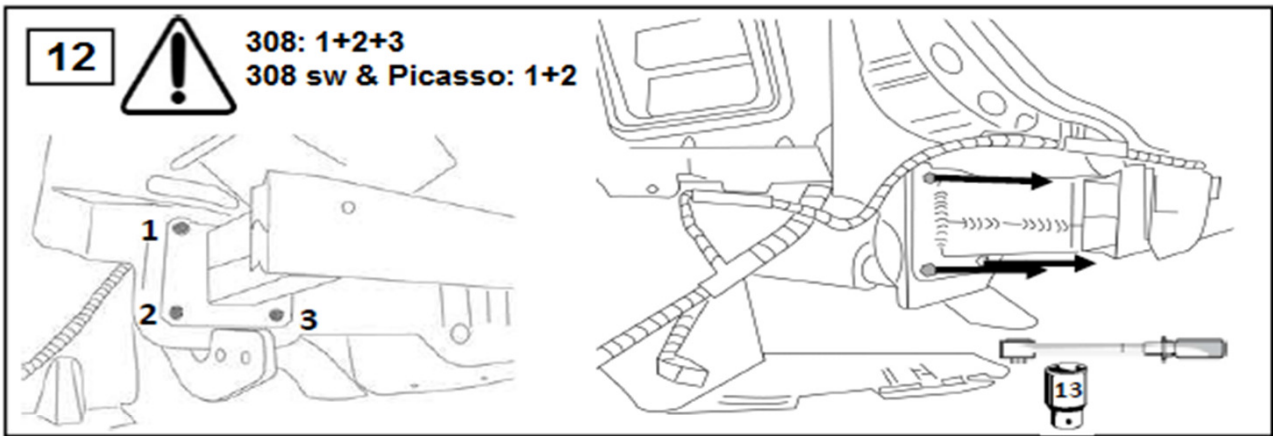
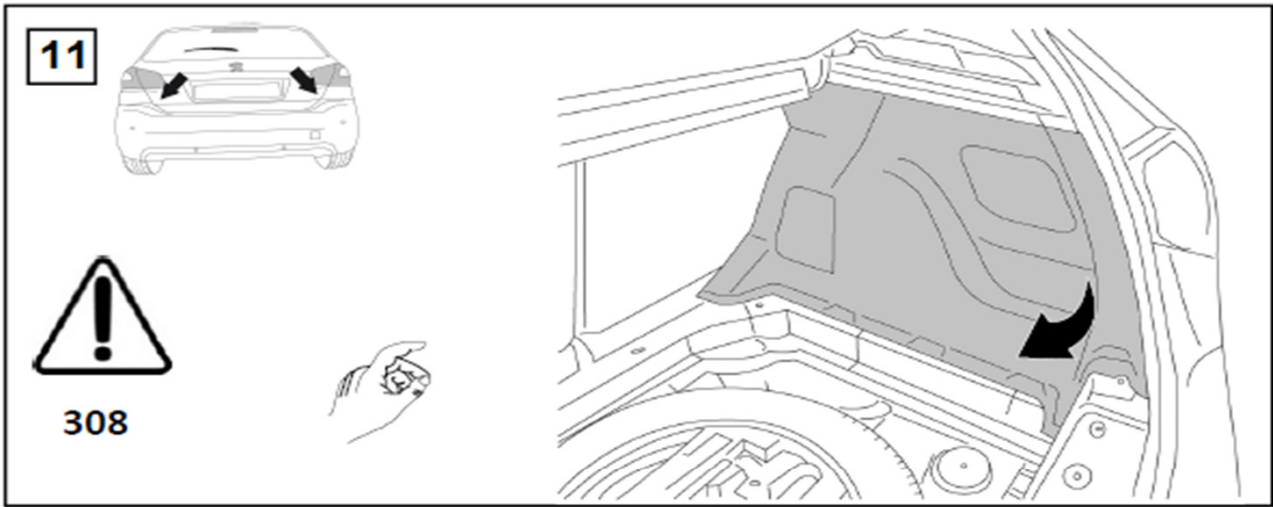

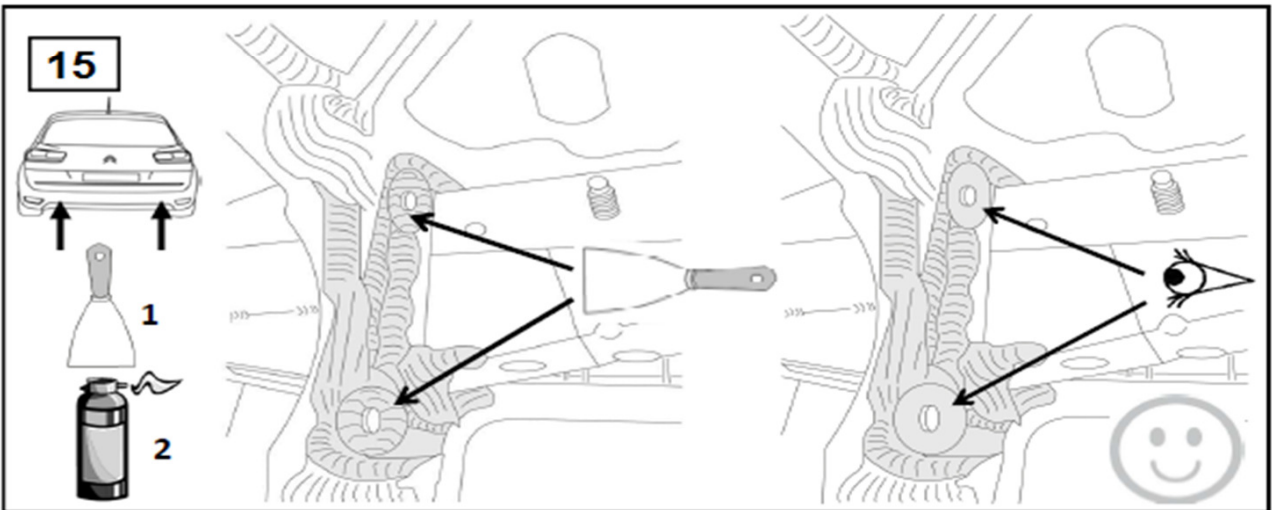
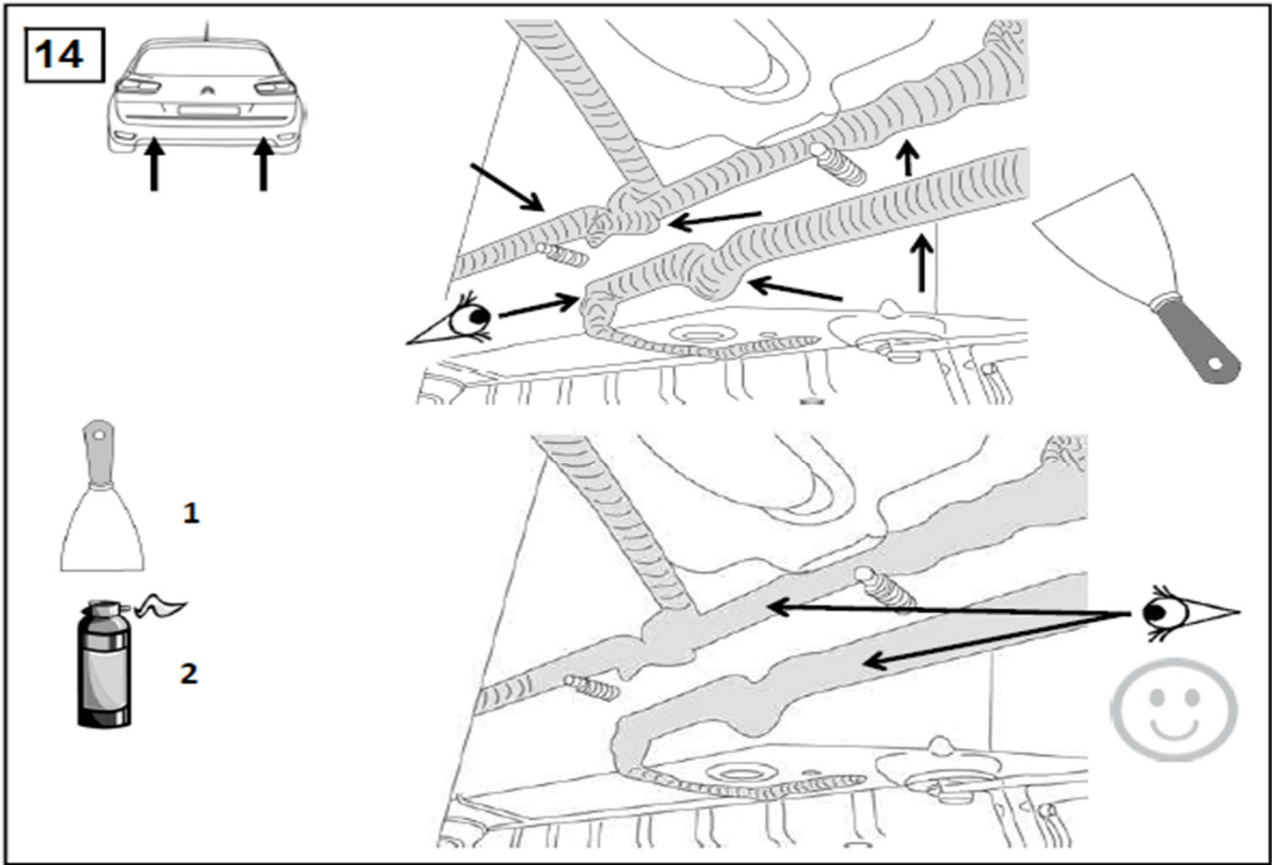

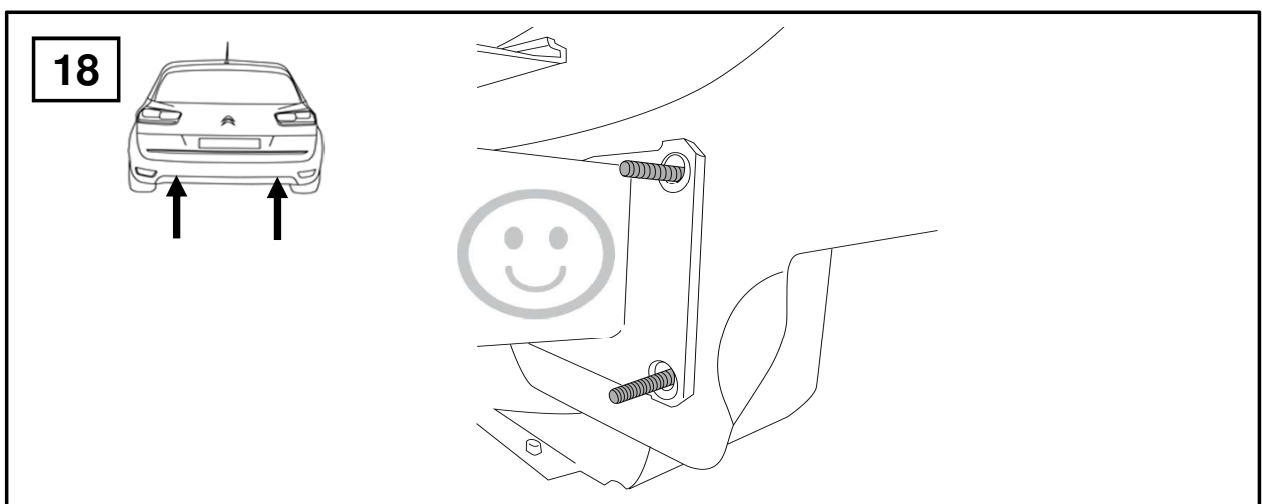
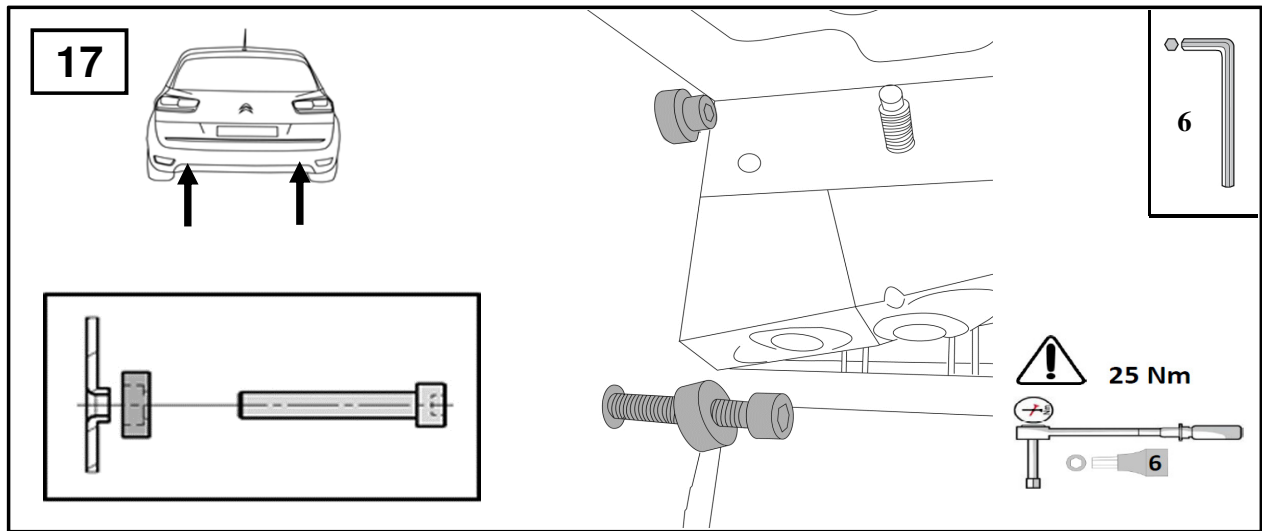
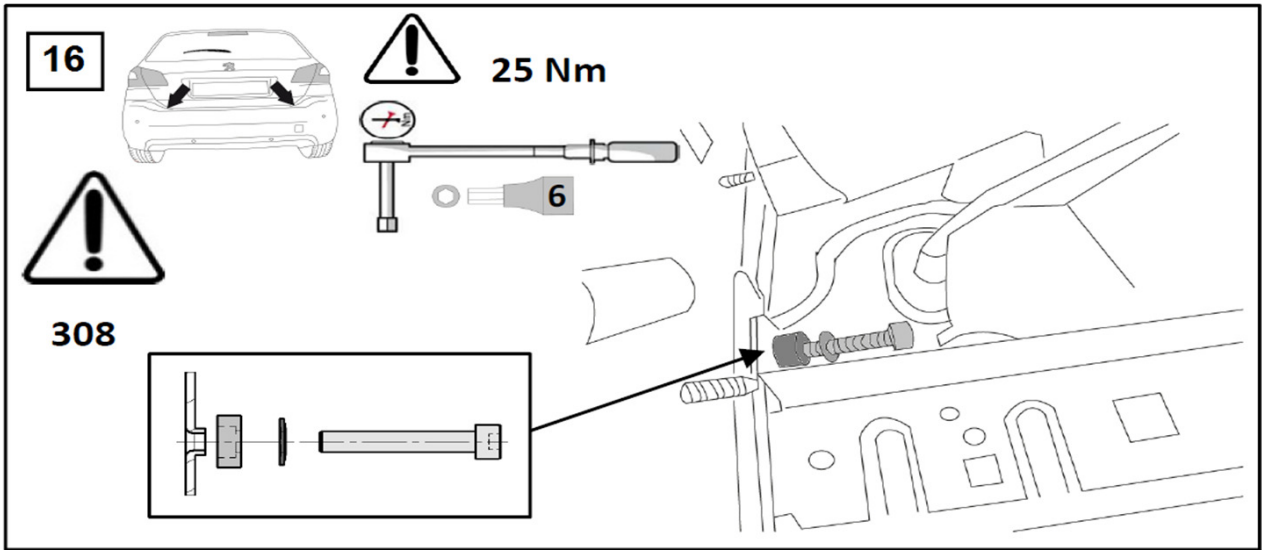

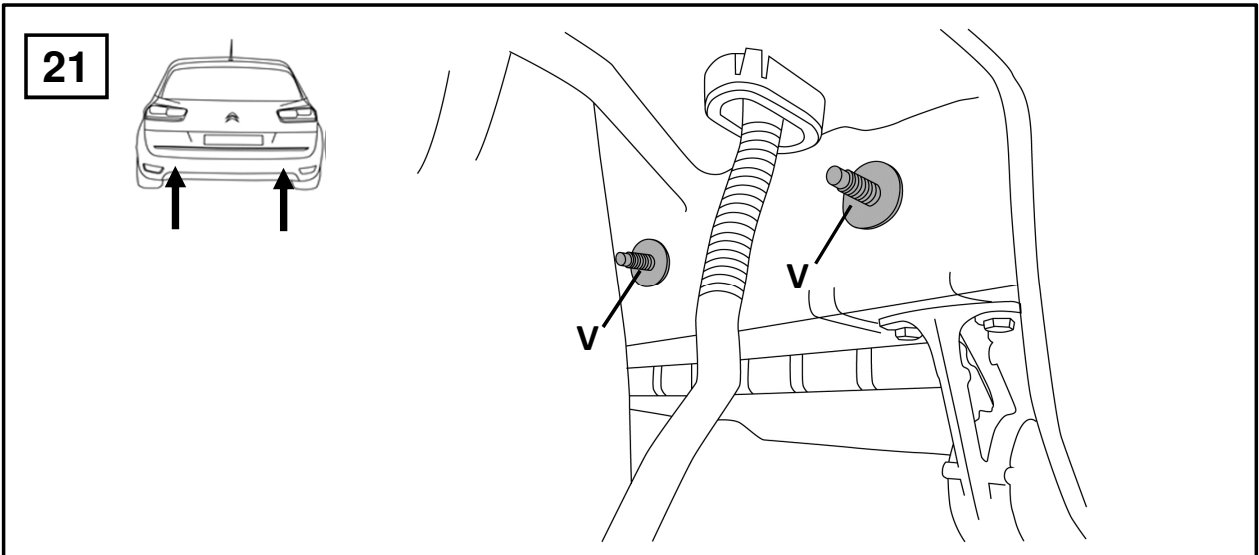
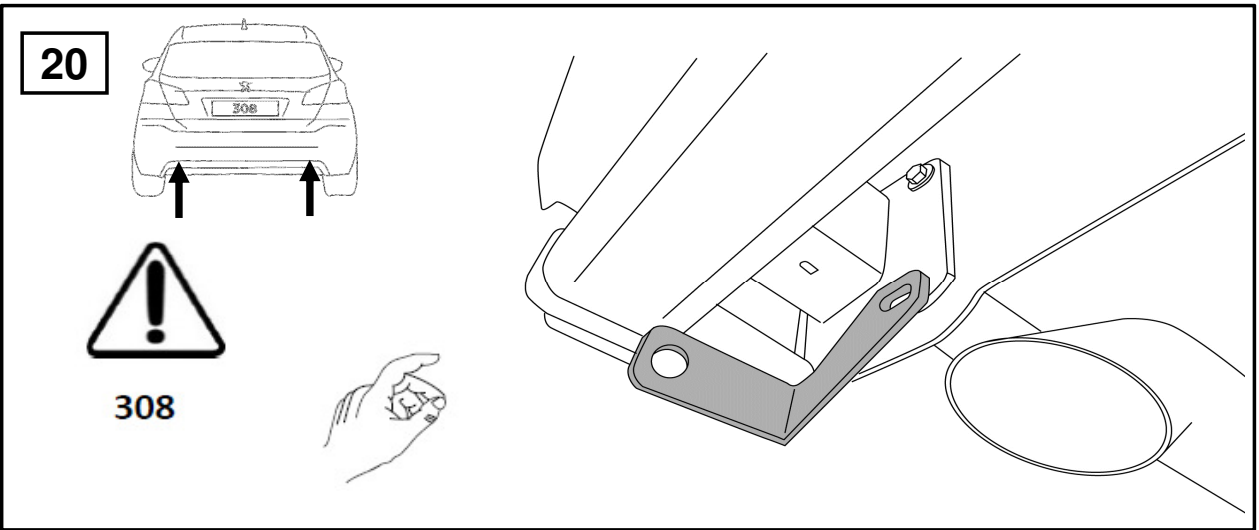
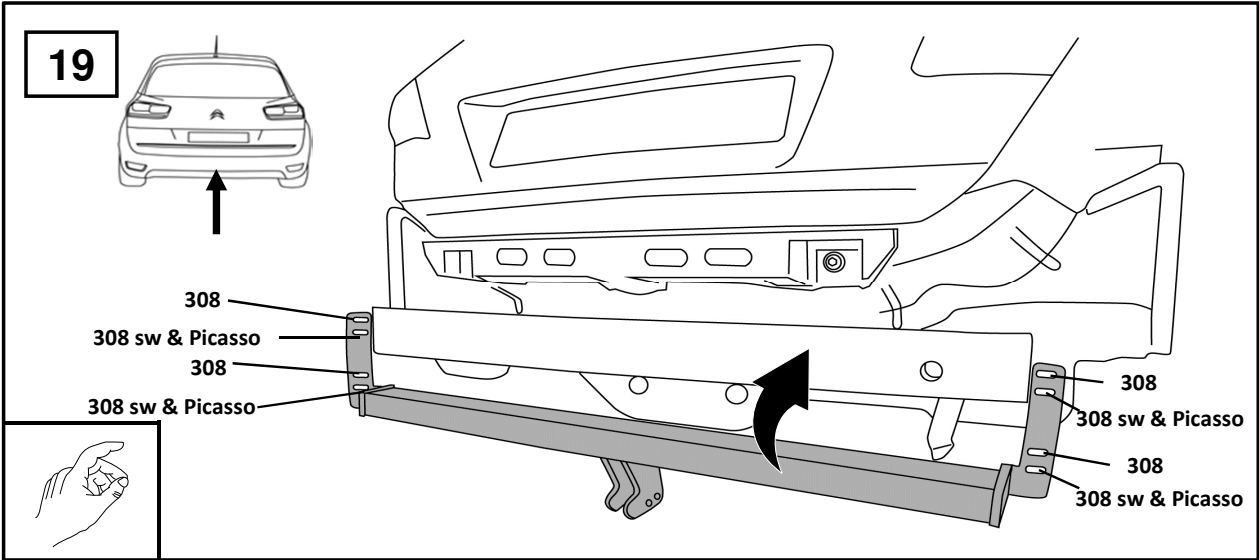

22

16
17

16
17

23

! M8 = 25 Nm
M10 = 47 Nm

16
17

13
16
17

24

! M8 = 25 Nm
M10 = 47 Nm

! (308)

16
17

13
16
17

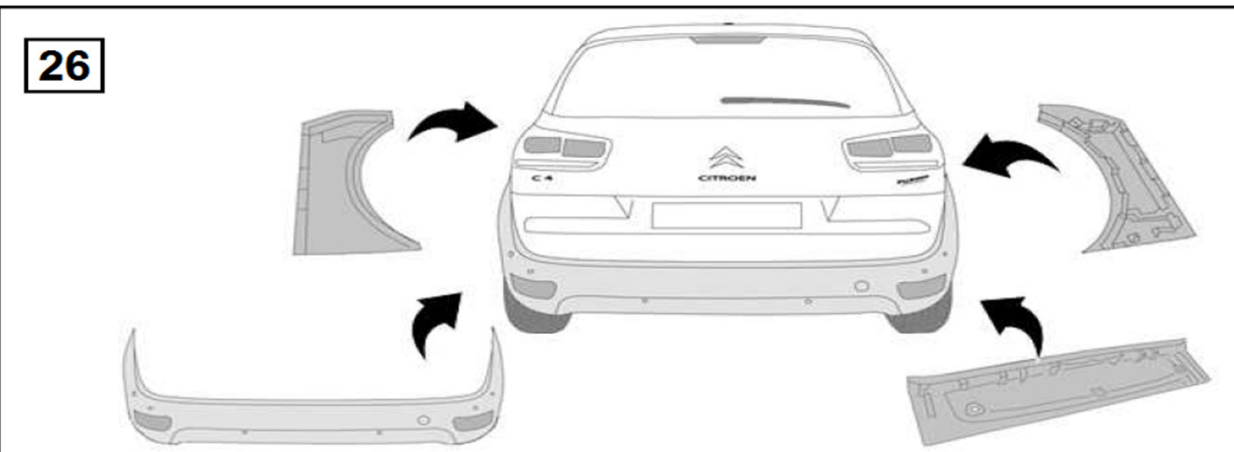
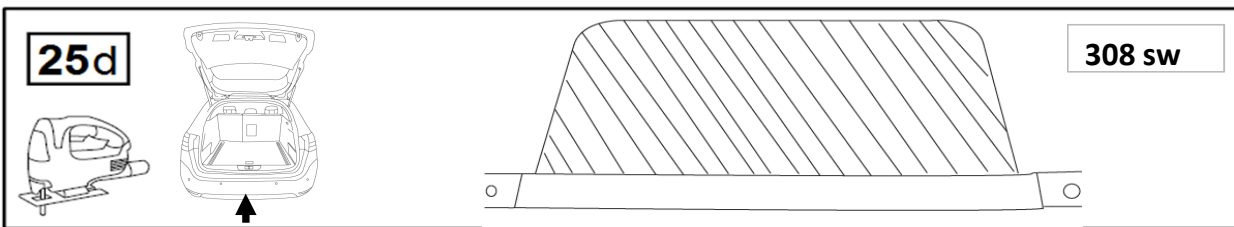
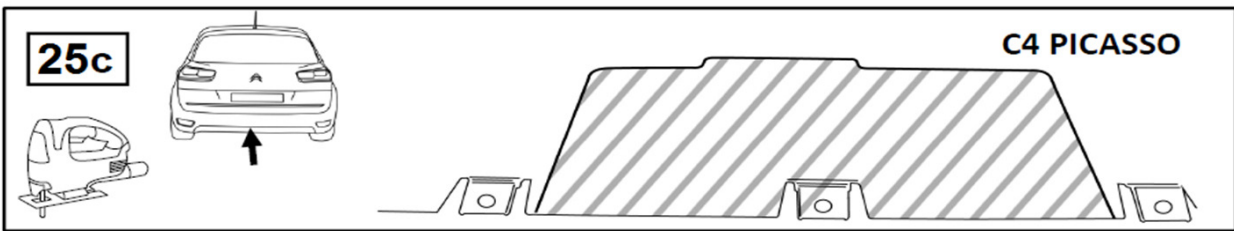
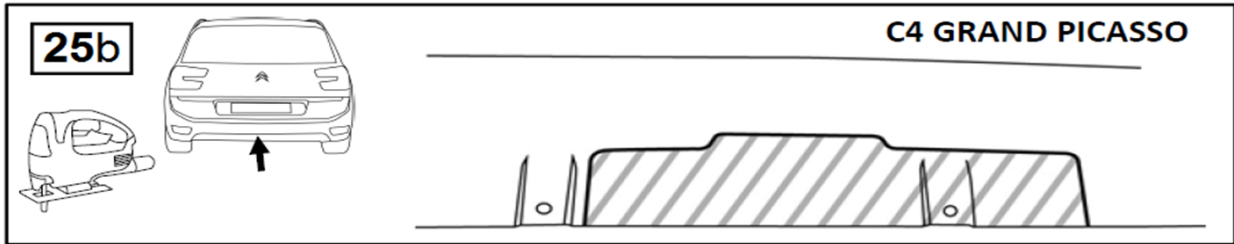
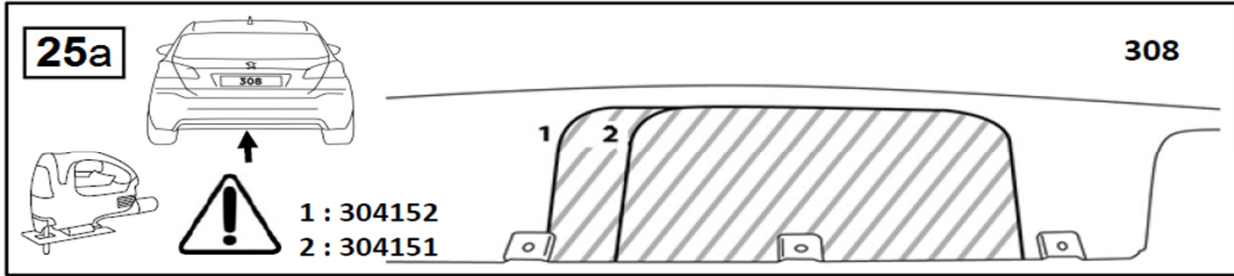
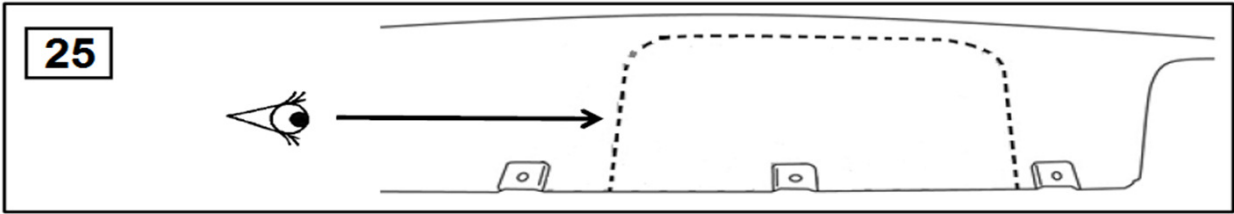

27

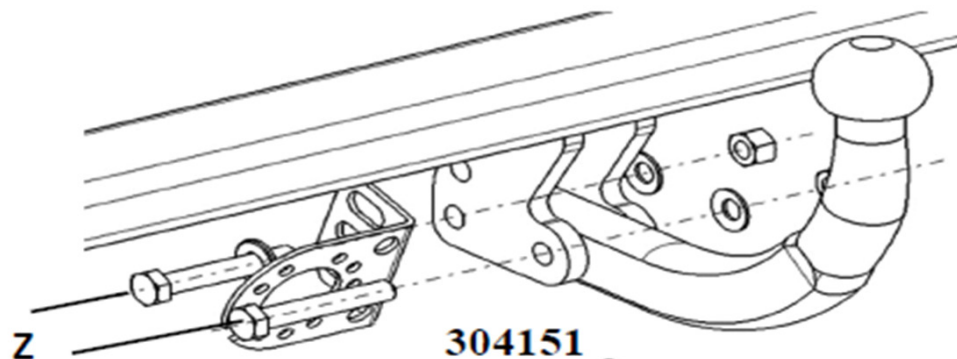

304151



M12 Cl8 = 81 Nm

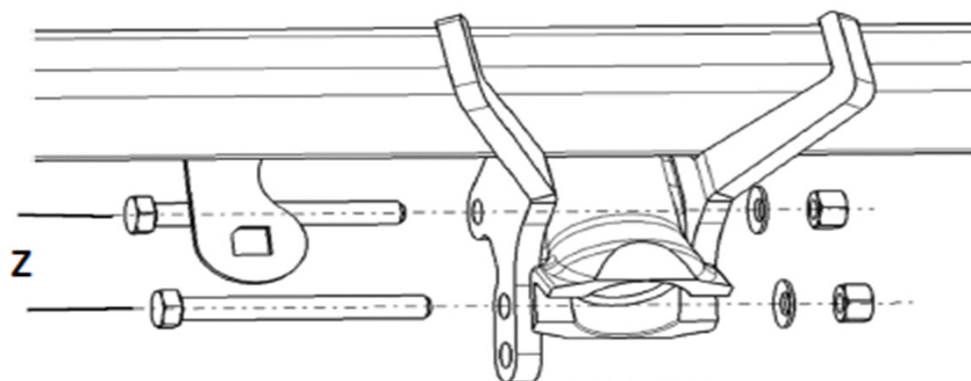

304152



M12 Cl10 = 114 Nm



18 - 19

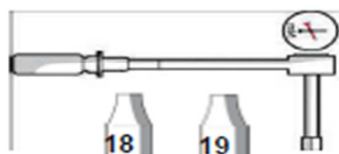

18

19

28

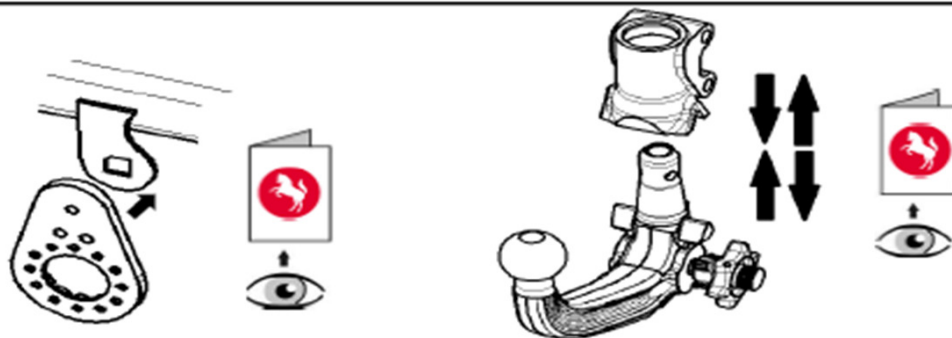



WESTFALIA AUTOMOTIVE

westfalia
AUTOMOTIVE



WESTFALIA AUTOMOTIVE

monoflex
WESTFALIA AUTOMOTIVE

Dispositivo di traino tipo : 304151/304152

Per autoveicolo : Peugeot 308 - Citroën C4 Picasso - Citroën C4 Grand Picasso

Tipo funzionale : L35FAG - L35FVG - LB9HCG - LB9 HPA - LPHMZA

VF73A - VF73D - VF73E

Classe e tipo di attacco : A50-X

Omologazione : e24*55R*01*0347 (304151) SI 119- e24*55R*01*0348 (304152) SI 120

Valore D : 9,5 kN

Carico verticale max. S : 75 kg

Massa rimorchiabile : vedi carta di circolazione dell'autoveicolo

In base alla Direttiva europea R55, la massa massima rimorchiabile del dispositivo di traino è determinata dal valore di prova "D" così definito :

$$D = (T \times C) / (T + C) \times 0,00981 = 9,5 \text{ kN}$$

dove : T = Massa complessiva max. della motrice (in kg) e C = Massa rimorchiabile max. della motrice (in kg)

DICHIARAZIONE DI CORRETTO MONTAGGIO :

la sottoscritta Ditta dichiara che il dispositivo di traino tipo _____ è stato installato a regola d'arte, nel rispetto dei punti d'attacco e delle prescrizioni fornite dalla Casa costruttrice

sul veicolo 308 / C4 PICASSO / C4 GRAND PICASSO

targato _____

li _____

timbro et firma

Si dichiara inoltre di aver informato l'utente del veicolo sull'USO e MANUTENZIONE del dispositivo stesso.