

# Artikel-Nummer. 701414

## AUDI

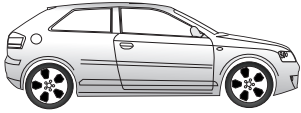

A3 3-türer  
A3 3 Door

05/03 →  
05/03 →



A3 Sportback

09/04 →

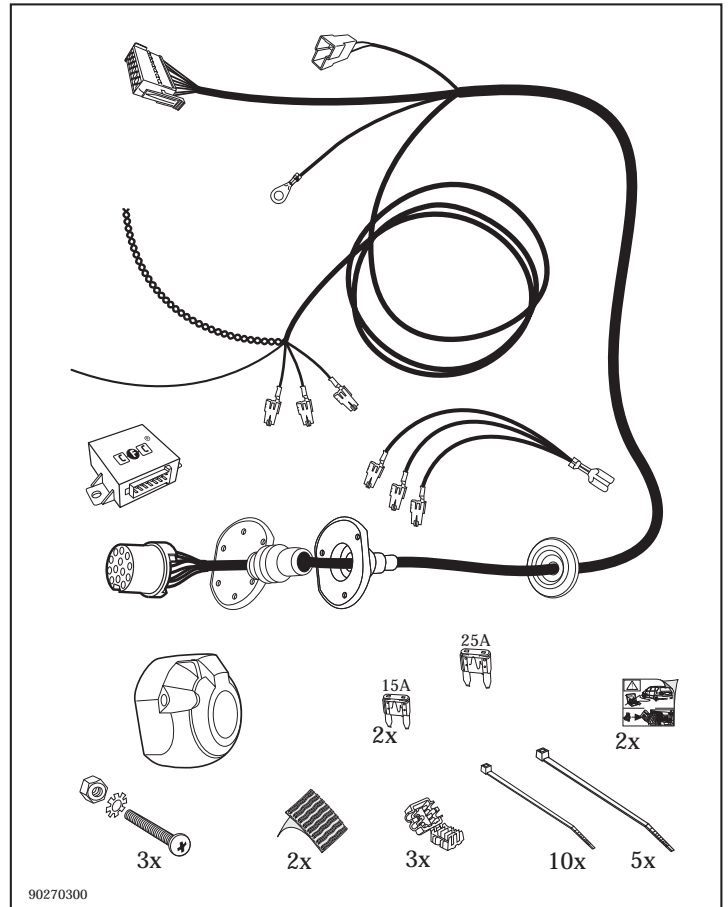
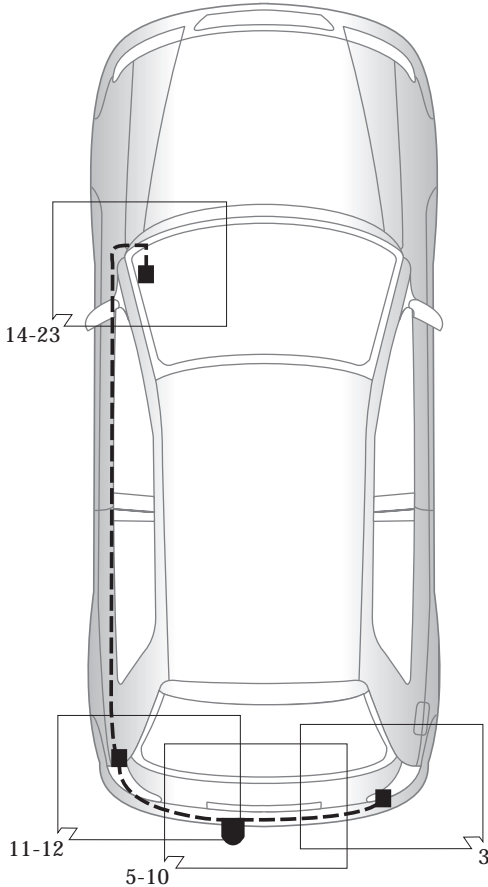

**!** Der Einbau dieses Elektrosatzes muß von einer Fachwerkstatt oder einer entsprechend qualifizierten Person durchgeführt werden. Vor Beginn aller Montagearbeiten unbedingt die Einbauanleitung komplett durchlesen. Nach Einbau des Elektrosatzes ist die Einbauanleitung den Serviceunterlagen des Fahrzeuges beizulegen!

**D** Bei unsachgemäßer Anwendung oder Veränderung des Elektrosatzes bzw. der darin befindlichen Bauteile erlischt jeder Anspruch auf Gewährleistung. Beim Fahren ohne Anhänger oder Ladungsträger müssen ggf. verwendete Adapter immer aus der Steckdose entfernt werden. Änderungen bezüglich Konstruktion, Ausstattung, Farbe sowie Irrtum vorbehalten. Alle Angaben und Abbildungen unverbindlich.

Bei Anhängern ohne Nebelschlussleuchte sollte diese nachgerüstet werden.

Für technische bzw. elektronische Änderungen, welche nach erstmaliger Inbetriebnahme des Elektrosatzes vom Fahrzeughersteller durchgeführt werden und beispielsweise zu Fehlfunktionen der Anhängersteckdose oder deren Peripherie führen, übernehmen wir keinerlei Gewährleistung!

Das Anhängermodul ist nicht diagnosefähig! Sollten herstellereigene Diagnoseprozesse bzw. softwaregestützte Prüfmechanismen Fehlerprotokolle generieren, welche direkt oder indirekt mit Anhängerbetrieb in Zusammenhang stehen, ist das Anhängermodul vom Leitungssatz für die Anhängersteckdose zu trennen und ein nochmaliger Diagnosevorgang zu starten!

**!** Installation of the towing electric kit must be undertaken by a specialist workshop or an appropriately qualified person. Before starting work, you must read the installation instructions through completely. After installing the towing electric kit, the installation instructions should be kept with the vehicle service documentation.

**GB** All claims under the guarantee will lapse in case of improper use or modification of the towing electric kit or any of its component parts. When driving without a trailer or load carrier, any adapter installed must be removed from the electrical socket. We reserve the right to alter the design, content or colour. We accept no liability for any errors in these instructions. All details and illustrations are non-binding.

In case of missing a rear fog lamp on the trailer, it should be retrofitted.

We accept no responsibility and give no guarantee for technical and electrical modifications made after the initial operation of the towing electric kit by the vehicle manufacturer and which may lead, for example to malfunction of the trailer socket or its peripheries.

The trailer module is not diagnostics-capable. If the manufacturer's diagnostics processes or software-supported test mechanisms generate error reports directly or indirectly linked with trailer operation, the trailer module must be disconnected from the leads to the trailer socket and a new diagnostic process initiated.

**!** Le montage du kit de connexion électrique doit être effectué par un atelier spécialisé ou par une personne qualifiée en la matière. Avant le début des travaux, lire impérativement les instructions de montage dans leur intégralité. Après le montage du kit de connexion électrique, joindre les instructions de montage aux documents du véhicule.

**F** Un usage inapproprié ou des modifications du kit de connexion électrique, ou des pièces qui le composent, entraînent l'expiration de tout droit à la garantie. Lors d'une conduite sans remorque ou porteur de charge, les adaptateurs utilisés doivent, le cas échéant, toujours être enlevés de la prise de courant. Sous réserve de modifications de constructions, équipement, couleurs ou erreur. Données et illustrations sous toute réserve.

Pour les remorques qui ne sont pas équipées avec feux anti-brouillard arrière, il devrait être installé.

Nous n'assumons aucune responsabilité ni garantie pour les modifications techniques et électroniques ayant été effectuées après la première mise en service du kit de connexion électrique par le constructeur automobile et ayant mené par exemple à des mauvais fonctionnements de la prise de remorque ou de sa périphérie.

Le module remorque ne contient pas de fonction diagnostic! Au cas où des processus de diagnostic définis par le fabricant ou des mécanismes de contrôle assistés par ordinateur devaient générer des messages d'erreur directement ou indirectement en rapport avec le fonctionnement de la remorque, il est impératif pour la prise de remorque de détacher le module remorque du groupe électrique et d'initier une nouvelle procédure de diagnostic.

**!** L'installazione del kit elettrico deve essere effettuata da un'officina o da personale specializzato. Prima di iniziare tutti i lavori di montaggio, leggere da cima a fondo le istruzioni. Dopo aver installato il kit elettrico si prega di allegare le istruzioni di montaggio ai documenti di manutenzione del veicolo!

In caso di uso improprio o di modifiche del kit elettrico e delle componenti del medesimo, ogni diritto di garanzia decade. Durante la guida senza rimorchio o portacarichi, togliere sempre gli adattatori dalla presa di corrente. Con riserva di modifiche relative a costruzione, equipaggiamento, colore e salvo errori. Tutte le indicazioni e illustrazioni non sono vincolanti.

In caso di rimorchi non corredati di luce retronebbia, questa dovrebbe essere installata.

Per le modifiche tecniche ed elettroniche eseguite dopo la prima messa in funzione del kit elettrico da parte del costruttore del veicolo, e che portano, per esempio, a un malfunzionamento della presa del rimorchio o della sua periferia, non assumiamo alcuna responsabilità. !

Il modulo del rimorchio non è idoneo alla diagnosi! Nel caso in cui processi diagnostici o apparecchiature di prova controllate da software dovessero generare dei protocolli d'errore in rapporto diretto o indiretto con l'uso del rimorchio, si deve staccare il modulo del rimorchio dal conduttore per la presa del rimorchio, e avviare nuovamente la diagnosi!

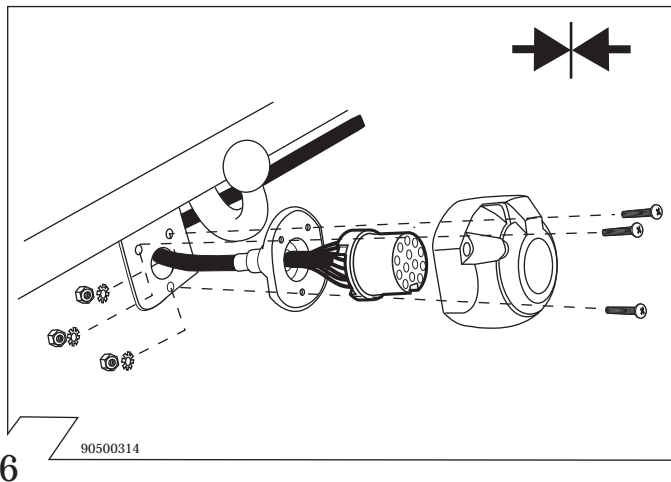
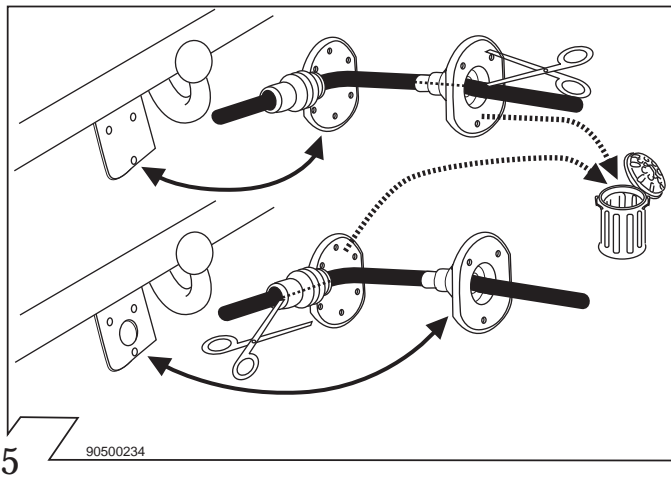
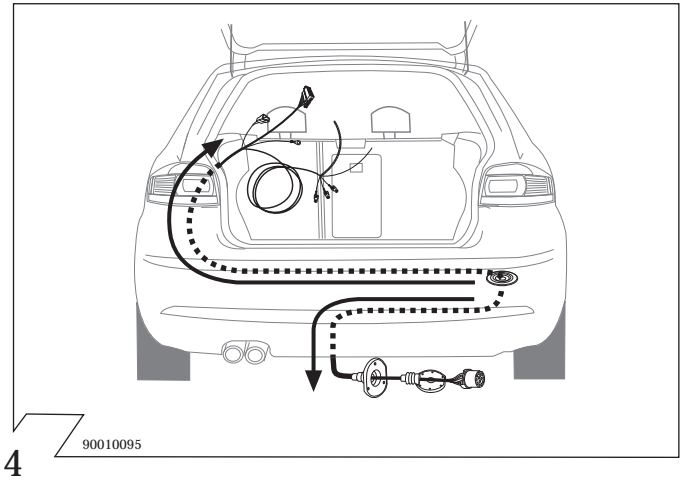
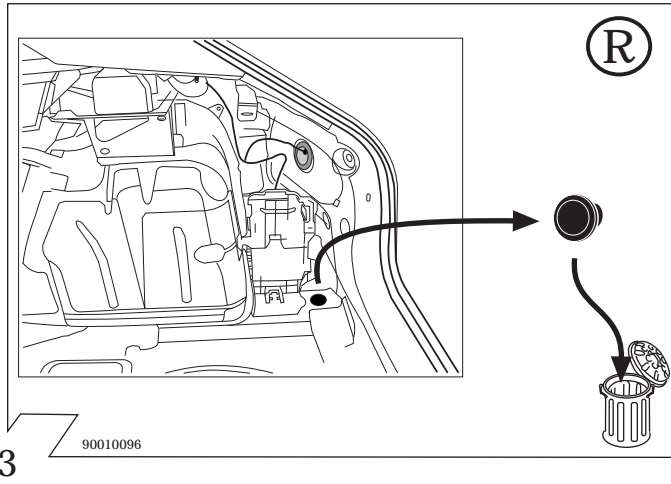
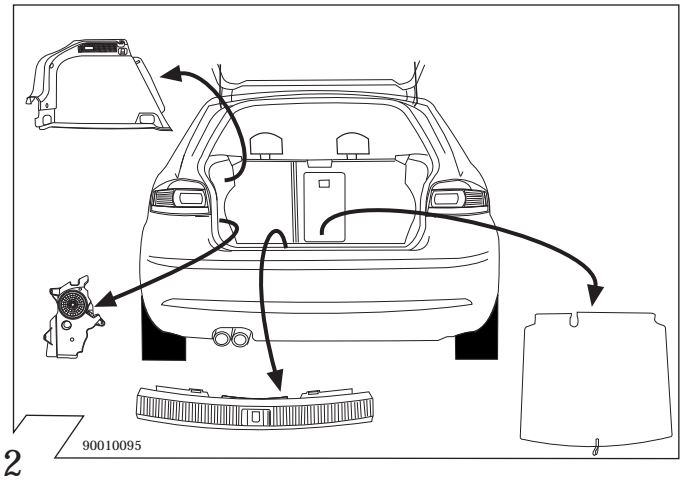
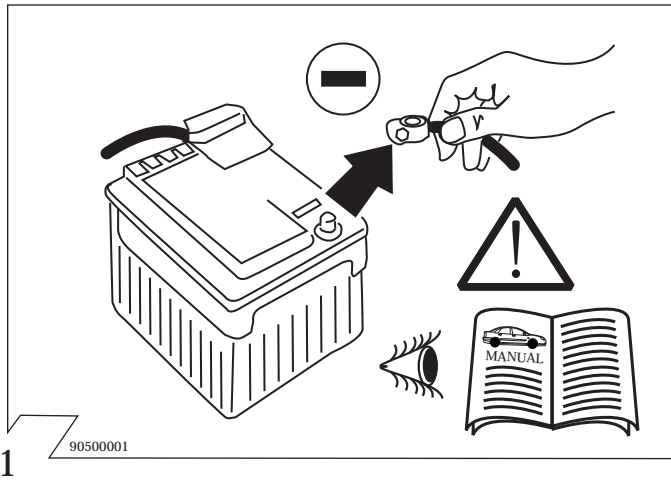

ISO 11446	Belegung der Steckdose / Maximale Ausgangsleistung Socket configuration / Maximum power output Correspondance des contacts de la prise / Puissance de sortie maximale Abbinamento della presa / Uscita di alimentazione massima		
	1/L	BK/WT	21W
	2	WT	42W
	3/31	BR	
	4/R	BK/GN	21W
	5/58-R	GY/RD	52W
	6/54	BK/RD	63W
	7/58-L	GY/BK	52W
	8	BL/RD	42W
	9	RD	240W
	10	YL	180W
	11	YL/BR	
	12		
	13	RD/BR	

7 90020157

	GB	D	E	F	I	P	NL	DK	N	S	FIN	CZ	H	PL
BK	Black	Schwarz	Negro	Noir	Nero	Preto	Zwart	Sort	Svart	Svart	Musta	Černá	Fekete	Czarny
RD	Red	Rot	Rojo	Rouge	Rosso	Vermelho	Rood	Rød	Rød	Röd	Punainen	Červená	Piros	Czerwony
GN	Green	Grün	Verde	Vert	Verde	Verde	Groen	Grøn	Grønt	Grön	Vihreä	Zelená	Zöld	Zielony
OR	Orange	Orange	Naranja	Orange	Arancione	Laranja	Oranje	Orange	Orange	Orange	Oranssi	Oranžová	Narancs	Pomarańczowy
VT	Violet	Violett	Violeta	Violet	Viola	Violeta	Violet	Violet	Fiolett	Violett	Violetti	Fialová	Ibolya	Fioletowy
PK	Pink	Pink	Pink	Rose	Rosa	Cor-de-Rosa	Paars	Pink	Pink	Rosa	Pinkki	Růžová	Rózsaszín	Różowy
BL	Blue	Blau	Azul	Bleu	Blu	Azul	Blauw	Blå	Blått	Blå	Sininen	Modrá	Kék	Niebieski
YL	Yellow	Gelb	Amarillo	Jaune	Giallo	Amarelo	Geel	Gul	Gult	Gul	Keltainen	Žlutá	Sárga	Żółty
WT	White	Weiss	Blanco	Blanc	Bianco	Branco	Wit	Hvid	Hvitt	Vit	Valkoinen	Bílá	Fehér	Biały
BR	Brown	Braun	Marrón	Brun	Marrone	Marrom	Bruin	Brun	Brunt	Brun	Ruskea	Hnědá	Barna	Brazowy
GY	Grey	Grau	Gris	Gris	Grigio	Cinzeno	Grijs	Grå	Grått	Grå	Harmaa	Šedá	Szürke	Szary

90500580  
8

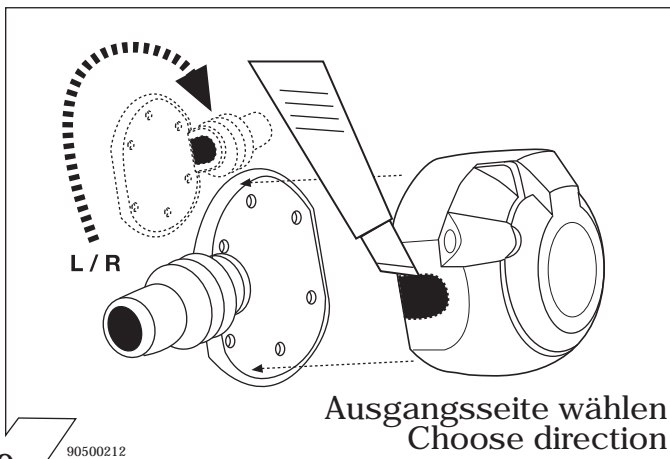

9

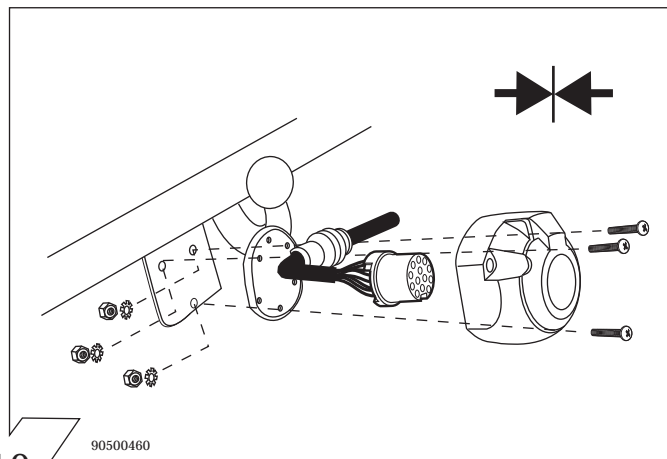

10

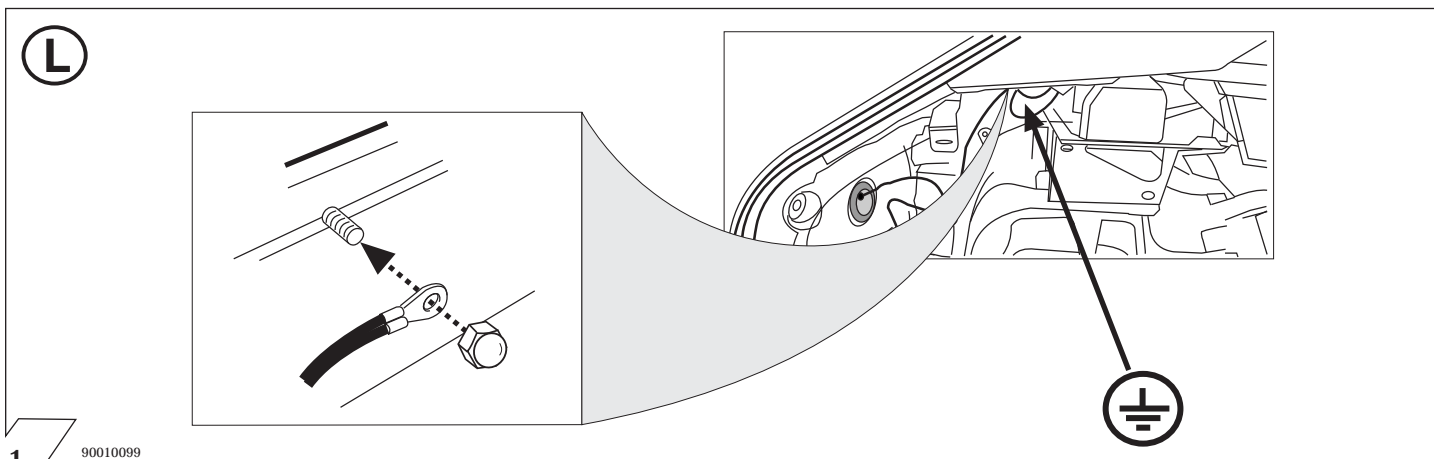

11

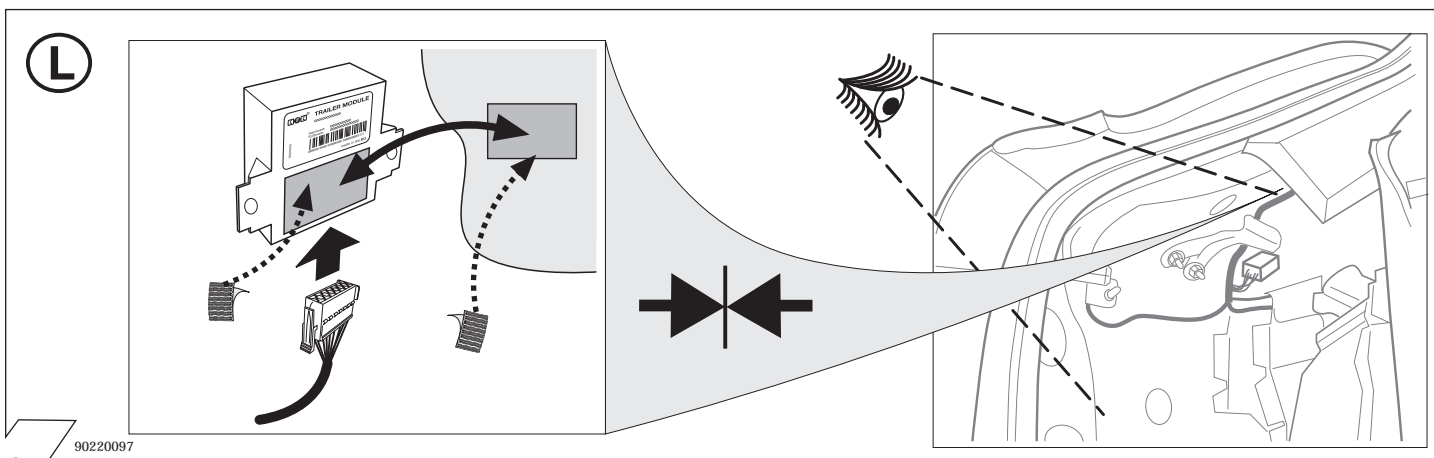

12

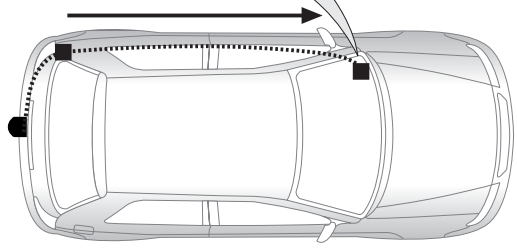
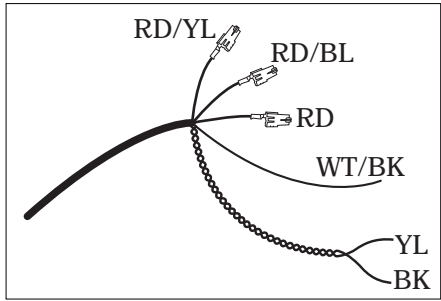

13

90270306

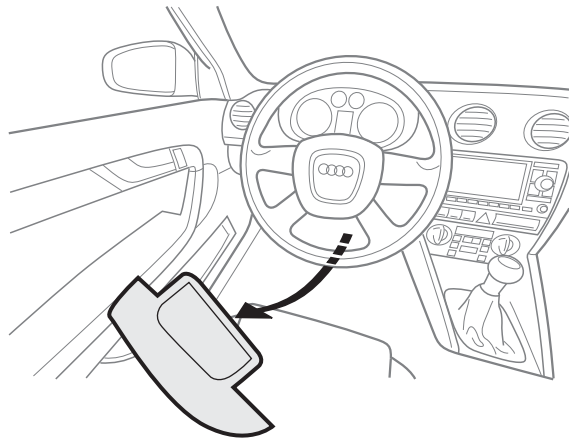

14

90270295

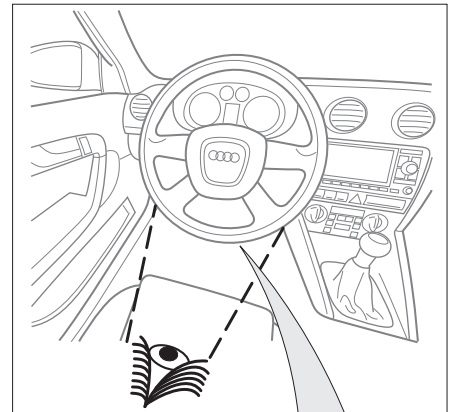
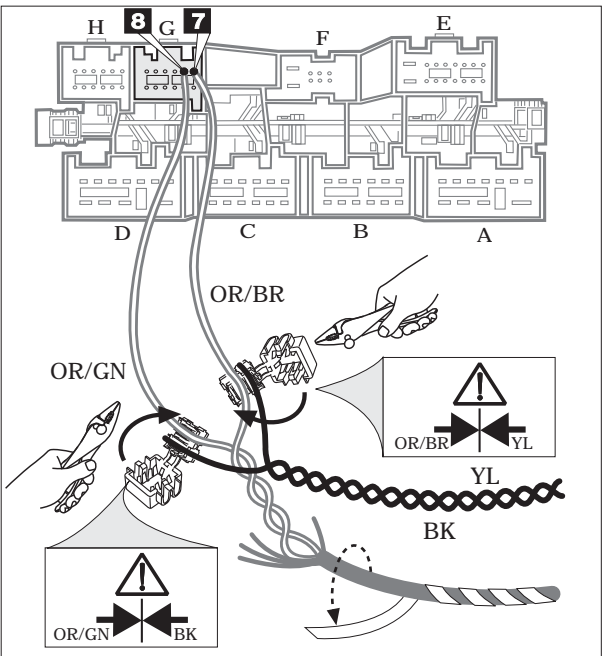

CAN-Data Wire OR/BR  
OR/GN



Bordnetzsteuergerät Position "G"  
Steckgehäuse 12-polig (BK)  
Kammern 7+8

Network control unit position "G"  
12 pin connector (BK)  
chambers 7+8

15

90270327

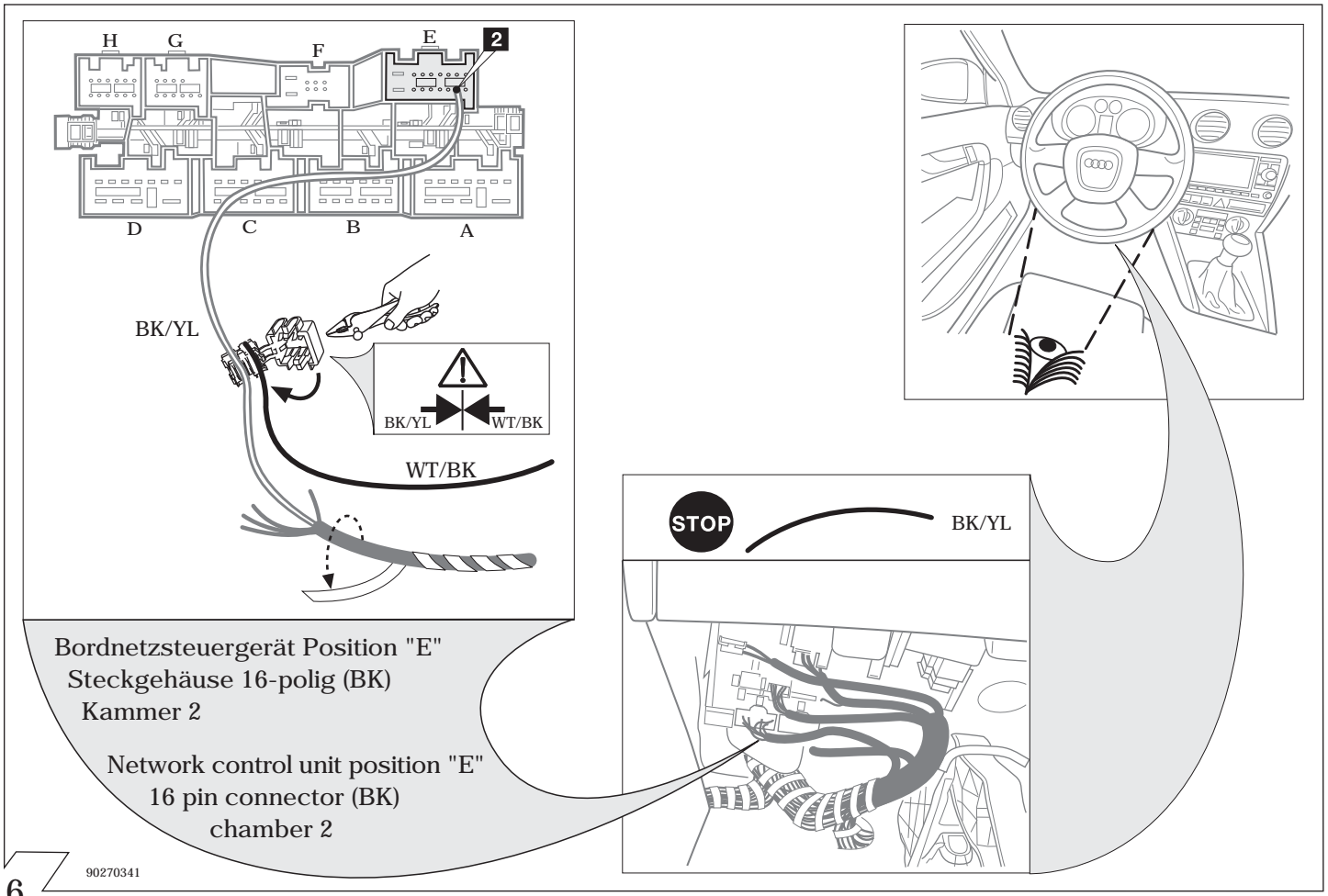

16

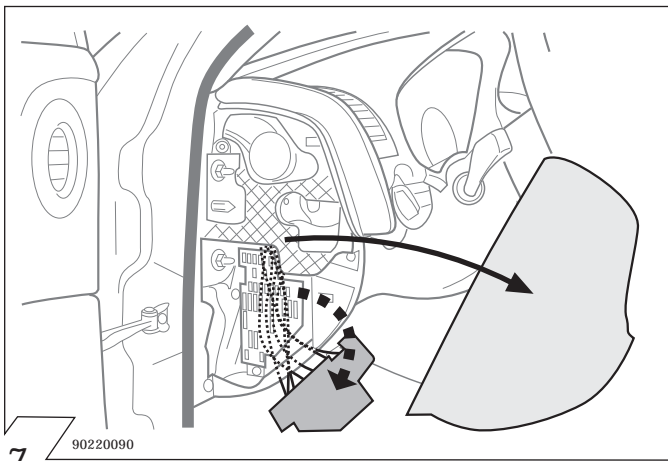

17

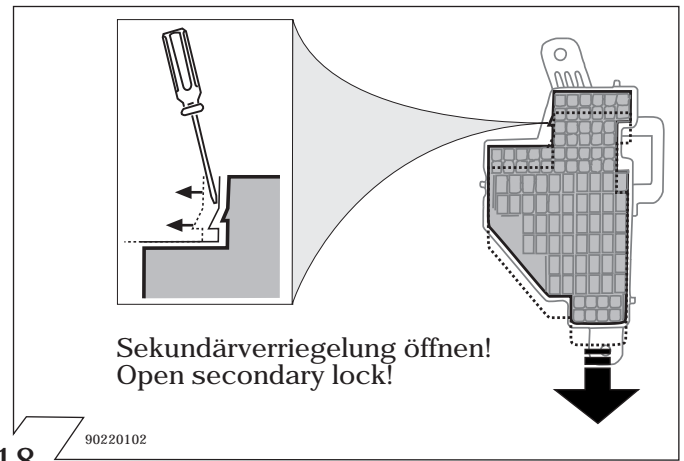

18

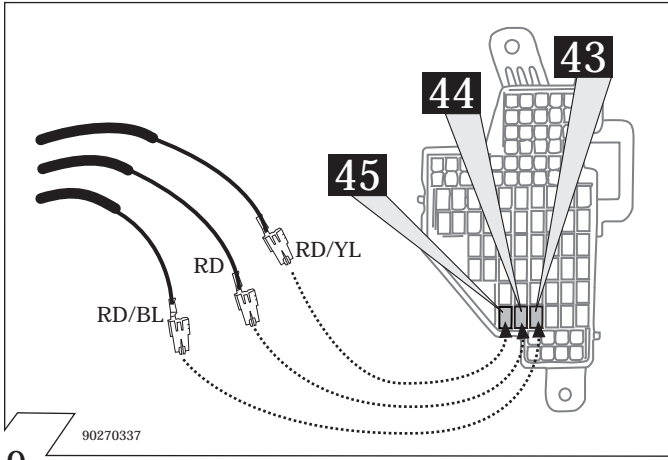

19

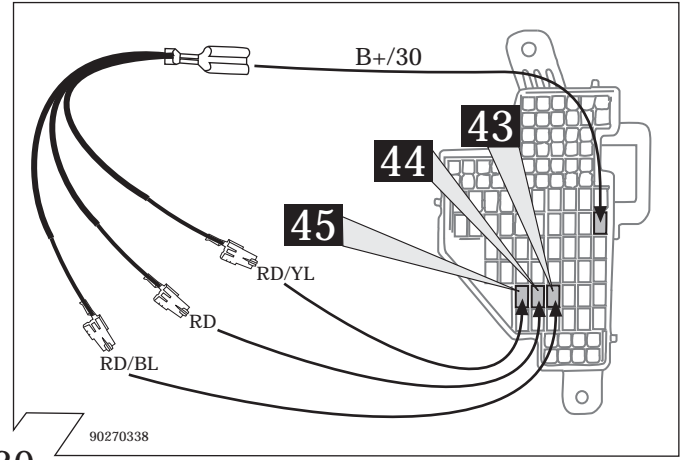

20



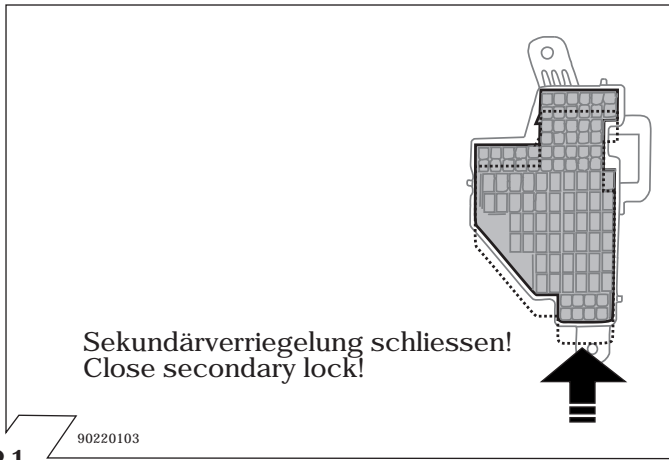

21

90220103

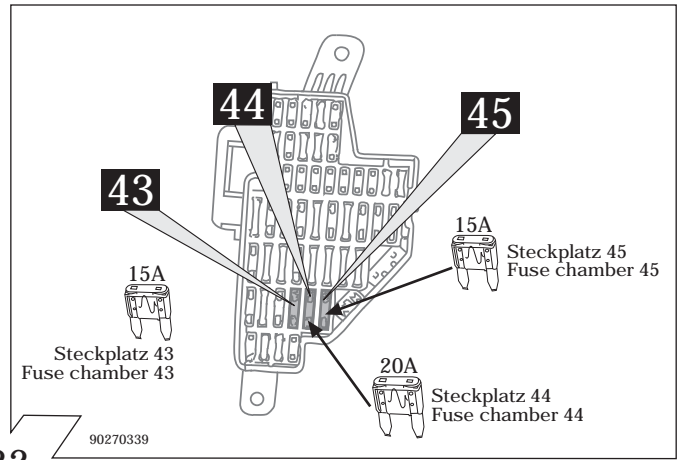

22

90270339

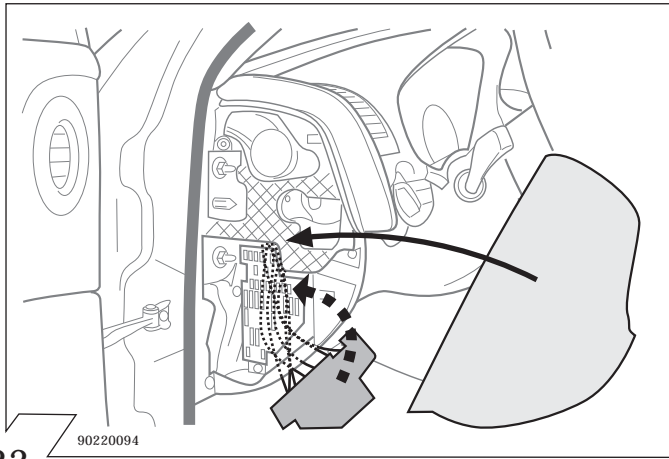

23

90220094

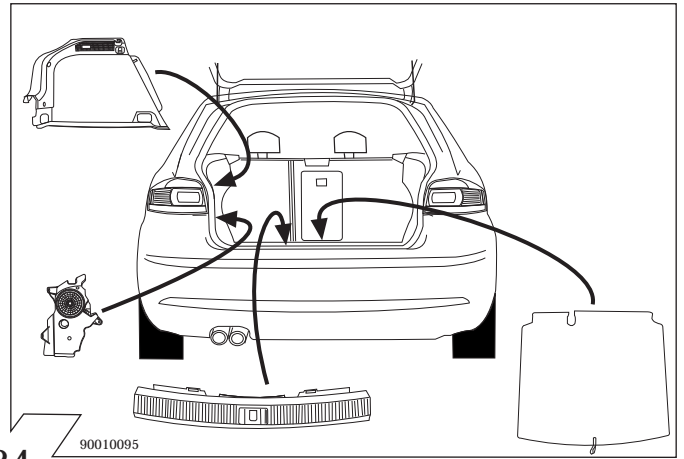

24

90010095

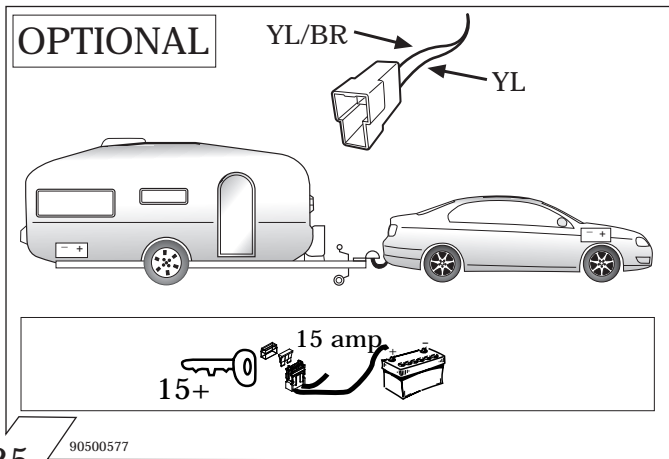

25

90500577

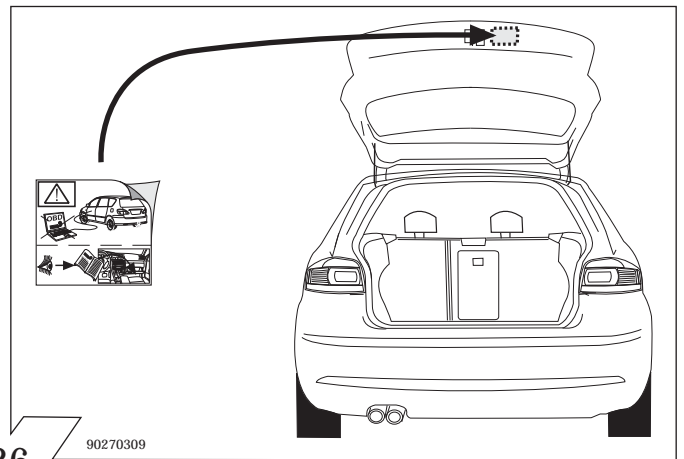

26

90270309

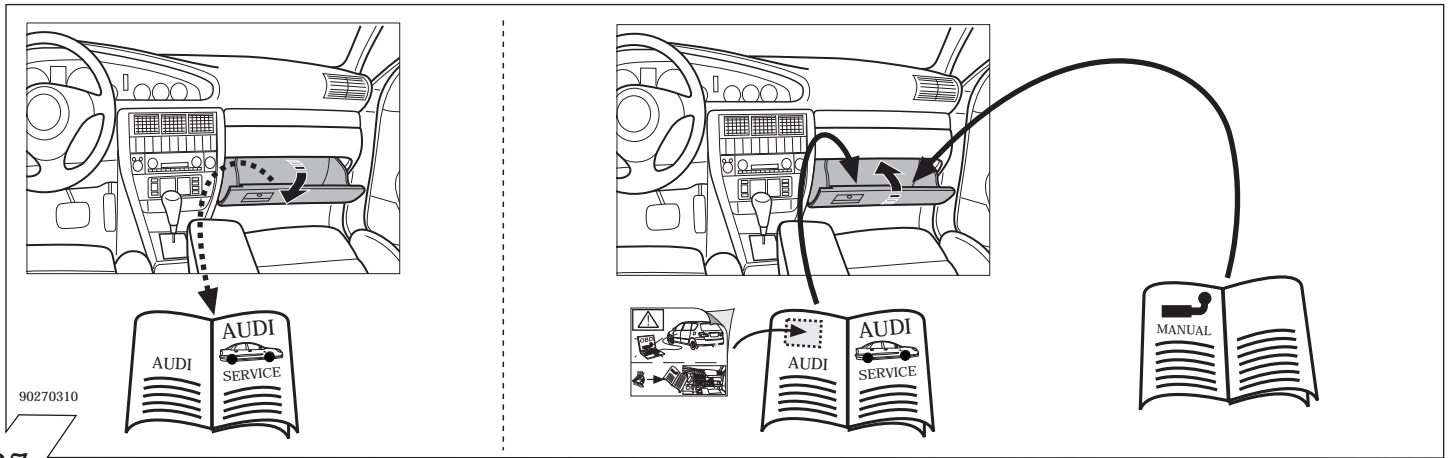

27

90270310

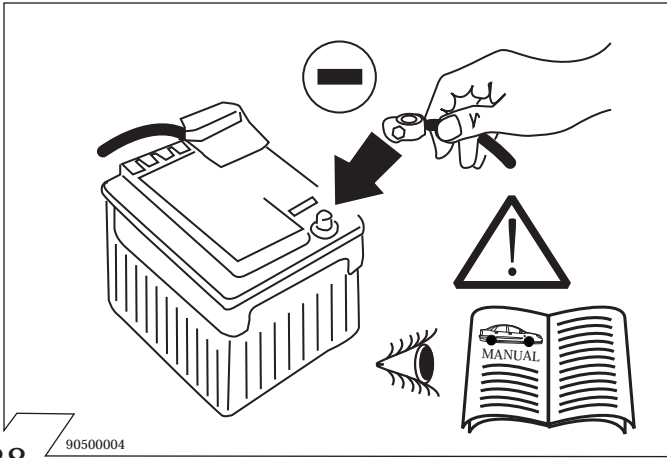

28

90500004

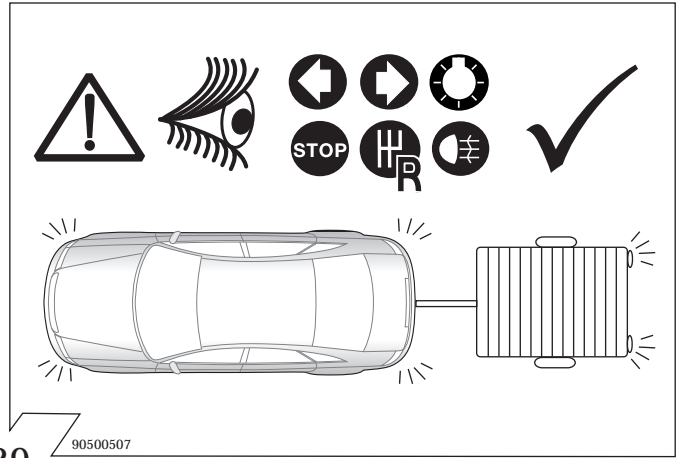

29

90500507

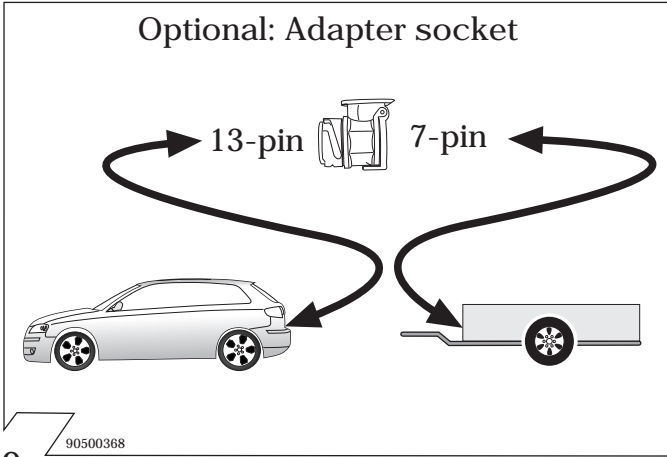

30

90500368

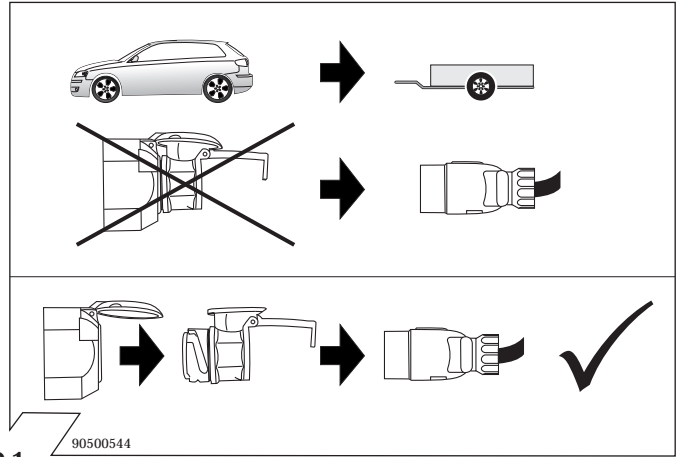

31

90500544

**Codierung Steuergerät**

**Seite 8**



**Code Control unit**

**page 8**

**Codage dispositif de commande**





**page 8**

**Codifica dispositivo di controllo**

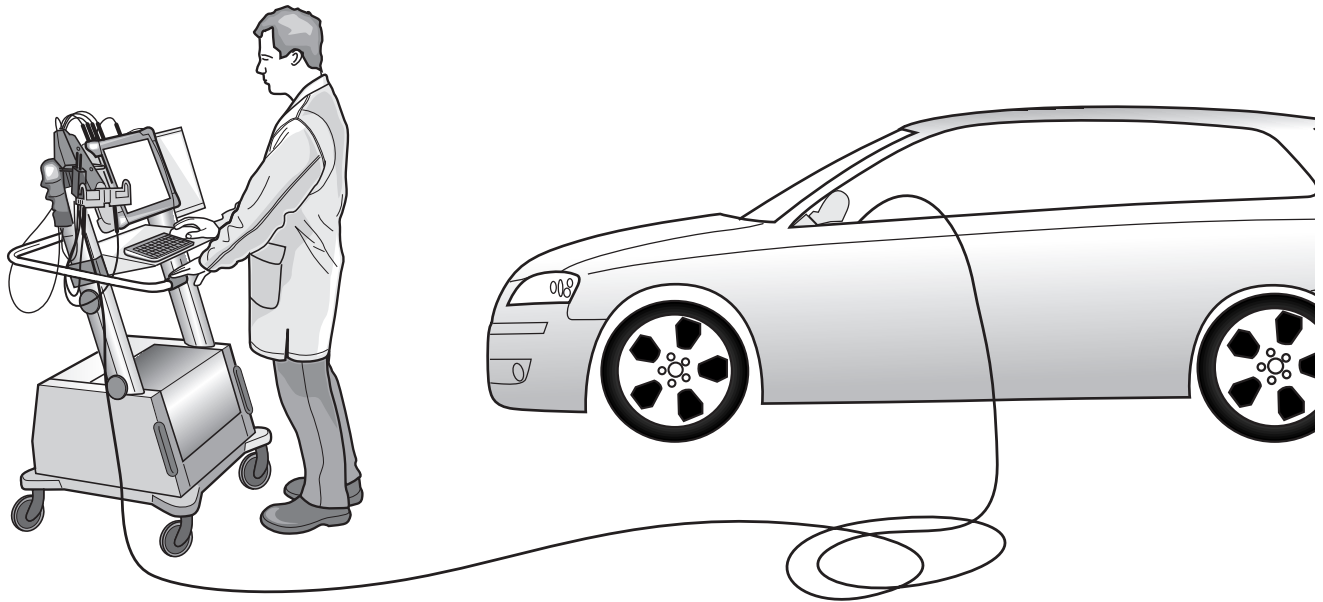
**pagina 8**

# Anhängerbetrieb konfigurieren / Set up trailer operation



 <b>D</b>	 <b>GB</b>	 <b>F</b>	 <b>I</b>
<p><b>Allgemein</b></p> <p>Nach Einbau des E-Satzes sind die obligatorische Anhängerbeleuchtung sowie die in einigen Ländern gesetzlich vorgeschriebene Anhängerblinküberwachung ohne jede Freischaltung am Fahrzeug gewährleistet!</p> <p>Es wird jedoch die Meldung "Steuergerät falsch codiert" im Fehlerspeicher hinterlegt ( 19 - Diagnoseinterface für Datenbus)! Dieser Eintrag hat allerdings keine Auswirkung auf weitere Funktionen und kann bis zum nächsten planmäßigen Werkstattaufenthalt ignoriert werden. Wir empfehlen eine Freischaltung mittels herstellereigenen Service-Testers (VAS 5051 / 5052) im Rahmen der jährlichen Serviceintervalle!</p> <p>Codierung bitte wie folgt durchführen:</p> <ul style="list-style-type: none"> <li>· Fahrzeug-Eigendiagnose</li> <li>· Gateway-Verbauliste</li> <li>· 19 - Diagnoseinterface für Datenbus</li> <li>· Lange Codierung lesen / schreiben</li> <li>· 69 - Anhängerfunktion ( auf codiert schalten!)</li> </ul> <p><b>Fahrzeuge mit Einparkhilfe</b></p> <p>Die automatische Deaktivierung der rückwärtigen Einparkhilfe im Anhängerbetrieb wird durch nachfolgende Codierung des Einparkhilfe-Steuergeräts erreicht:</p> <ul style="list-style-type: none"> <li>· Fahrzeug-Eigendiagnose</li> <li>· Gateway-Verbauliste</li> <li>· 76 - Einparkhilfe</li> <li>· 07 - Steuergerät codieren</li> <li>· Den Wert 10000 zur aktuellen Codierung addieren &amp; neu programmieren</li> </ul>	<p><b>General</b></p> <p>After the installation of the electric kit, the obligatory trailer lighting as well as the trailer indicator control which is statutory in a several countries are guaranteed without having to make any connections on the vehicle!</p> <p>The message "Control unit incorrectly coded" will, however, appear in the fault memory ( 19 - Diagnosis interface for data bus)! Yet this entry has no effect on the other functions and can be ignored until your next regular service appointment. We recommend the connection via the factory-mounted service tester (VAS 5051 / 5052) within the framework of the annual service intervals!</p> <p>Please effect coding as follows:</p> <ul style="list-style-type: none"> <li>· Vehicle self-diagnosis</li> <li>· Gateway assembly list</li> <li>· 19 - diagnosis interface for data bus</li> <li>· Read / write long coding</li> <li>· 69 - trailer function ( switch to coded!)</li> </ul> <p><b>Vehicles with park assist systems</b></p> <p>The automatic deactivation of the rear park assist system in trailer operation will be effected by means of the subsequent coding of the park assist control unit:</p> <ul style="list-style-type: none"> <li>· Vehicle self-diagnosis</li> <li>· Gateway assembly list</li> <li>· 76 - park assist system</li> <li>· 07 - code control unit</li> <li>· Add the figure 10000 to the current coding &amp; reprogramme</li> </ul>	<p><b>Généralités</b></p> <p>Après l'installation du module électrique, l'éclairage obligatoire de la remorque ainsi que le contrôle des clignotants de la remorque, prescrit dans certains pays, sont assurés sans qu'il soit nécessaire d'activer ces fonctions dans le véhicule!</p> <p>Toutefois, le message «mauvais codage du dispositif de commande» sera affiché dans la mémoire d'erreurs ( 19 - interface de diagnostic pour bus de données)! Or, ce message n'a aucune influence sur les autres fonctions et il n'est pas nécessaire de s'en occuper jusqu'au prochain service prévu dans un garage. Nous vous recommandons d'activer ces fonctions à l'aide d'un testeur de service du fabricant (VAS 5051 / 5052) dans le cadre des intervalles annuels de service!</p> <p>Veillez effectuer le codage comme il suit:</p> <ul style="list-style-type: none"> <li>· autodiagnostic du véhicule</li> <li>· liste d'assemblage gateway</li> <li>· 19 - interface de diagnostic pour bus de données</li> <li>· lire / écrire un code long</li> <li>· 69 - mode remorque ( commuter à encodé!)</li> </ul> <p><b>Véhicules avec système d'aide au parking</b></p> <p>L'aide au parking arrière est désactivée automatiquement dans le mode remorque par le codage suivant du dispositif de commande du système d'aide au parking:</p> <ul style="list-style-type: none"> <li>· autodiagnostic du véhicule</li> <li>· liste d'assemblage gateway</li> <li>· 76 - aide au parking</li> <li>· 07 - coder le dispositif de commande</li> <li>· additionner la valeur 10000 au code actuel et effectuer un nouveau paramétrage</li> </ul>	<p><b>Informazioni generali</b></p> <p>Dopo il montaggio del gruppo elettronico, l'illuminazione obbligatoria e il controllo dei lampeggianti del rimorchio (prescritto dalla legge in alcuni paesi) sono assicurati senza bisogno di alcuna procedura di attivazione!</p> <p>Tuttavia, il messaggio di errore „Codifica del dispositivo di controllo non corretta“ è registrata nella memoria ( 19 - Interfaccia di diagnosi per il data bus)! Questa registrazione non ha comunque alcun effetto sulle ulteriori funzioni, e può essere ignorata fino alla prossima manutenzione periodica da eseguire in officina. Consigliamo di eseguire l'attivazione con il tester di servizio originale del costruttore (VAS 5051 / 5052) nel quadro della manutenzione annuale!</p> <p>Si prega di eseguire la codifica come segue:</p> <ul style="list-style-type: none"> <li>· Autodiagnosi del veicolo</li> <li>· Lista del Gateway</li> <li>· 19 - Interfaccia di diagnosi per il data bus</li> <li>· Lettura e scrittura di codici lunghi</li> <li>· 69 - Funzione rimorchio (commutare su codificato!)</li> </ul> <p><b>Veicoli con sensori di parcheggio</b></p> <p>La disattivazione automatica dei sensori di parcheggio posteriori quando è attaccato un rimorchio si ottiene attraverso la seguente programmazione della centralina di controllo dei sensori:</p> <ul style="list-style-type: none"> <li>· Autodiagnosi del veicolo</li> <li>· Lista d'installazione Gateway</li> <li>· 76 - Sensori di parcheggio</li> <li>· 07 - Codificare la centralina di controllo</li> <li>· Aggiungere il valore 10000 al codice attuale e riprogrammare</li> </ul>