

Towbar

6083

Toyota

• Hi-Lux

2015/04->

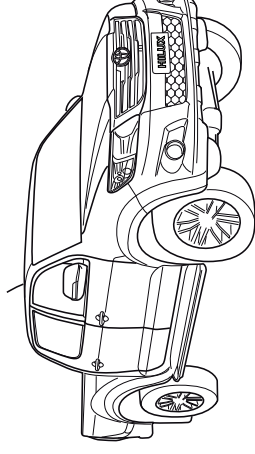

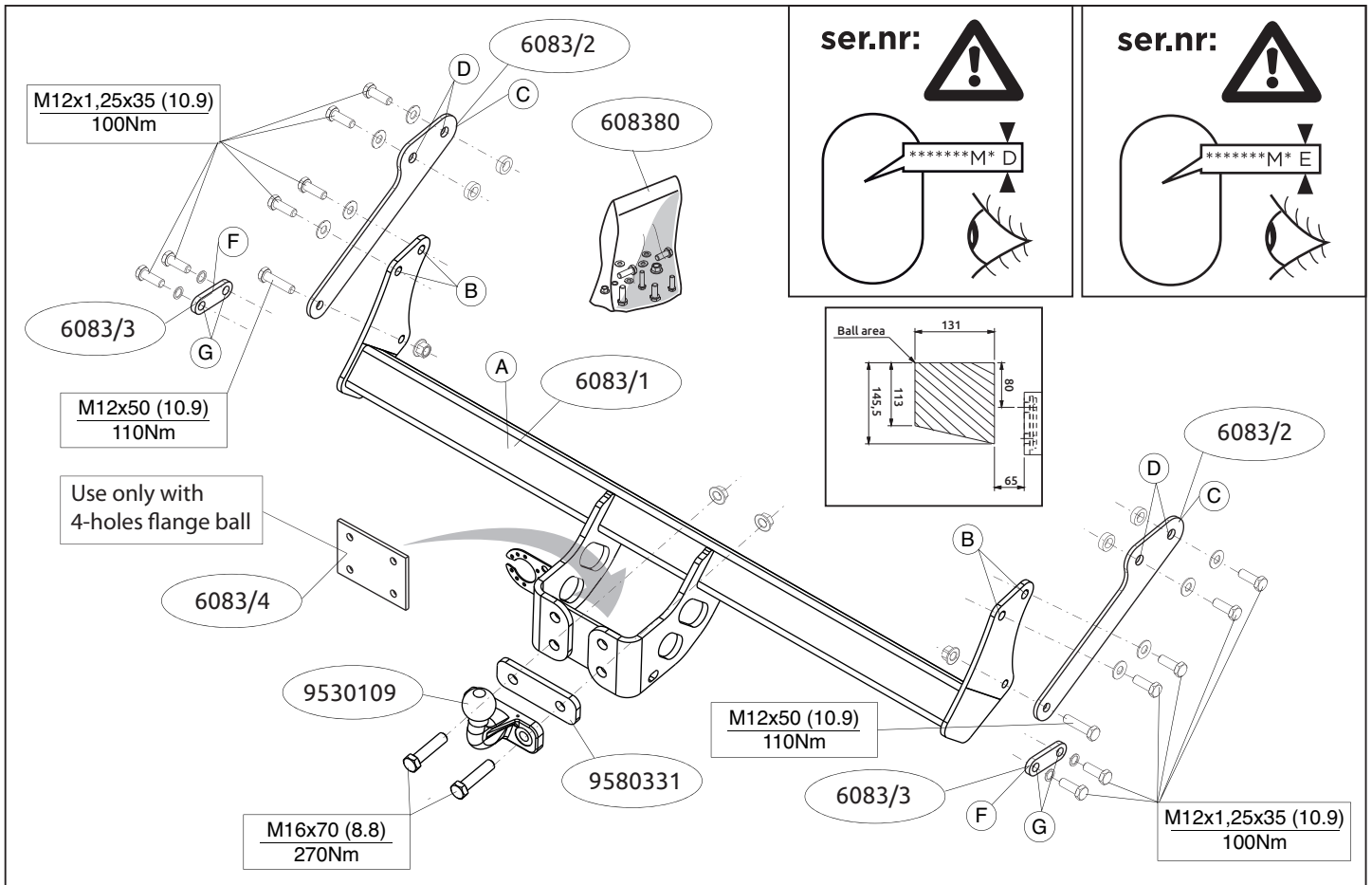

© 608370/02-09-2016/1



Dispositivo di traino tipo: 6083
Per autoveicoli: Toyota Hi-Lux: 2015/04->
Tipo funzionale: GUN 1***-****HW

Classe e tipo di attacco: A50-X
Omologazione: E11 55R 0110646
Valore D: 17,2 kN
Carico Verticale max. S: 140 kg
Larghezza rimorchiabile per Caravan e T.A.T.S.: 2,45m vedere CARTA di CIRCOLAZIONE VEICOLO (motrice) + 70 cm = ..arrotondare ai 5 cm superiore (vedi D.M.28/05/85)
Massa rimorchiabile: vedi carta di circolazione dell' autoveicolo

Per verificare l'idoneità del dispositivo di traino omologato a norma UN ECE R55, all'installazione sulla vettura su cui si intende procedere al montaggio, compilare la seguente formula (se necessario declassare la massa rimorchiabile):

$$D = \frac{T \times C}{T + C} \times 0,00981 \leq 17,2 \text{ kN}$$

dove: T= Massa Complessiva Max. della motrice (in kg)
C= Massa Rimorchiabile Max. della motrice (in kg)

DA COMPILARE PER IL COLLAUDO

DICHIARAZIONE DI CORRETTO MONTAGGIO: la sottoscritta Ditta dichiara di aver montato in maniera corretta ed in conformità/alle prescrizioni sia del costruttore del veicolo che del costruttore del dispositivo stesso il seguente dispositivo di attacco meccanico:

tipo:.....
Il dispositivo di attacco sopra indicato è stato installato su autoveicolo
modello:.....
targa:.....
Data:.....

TIMBRO e FIRMA

Si dichiara inoltre di aver informato l'utente del veicolo sull'USO e MANUTENZIONE del dispositivo stesso.

© 608370/02-09-2016/14

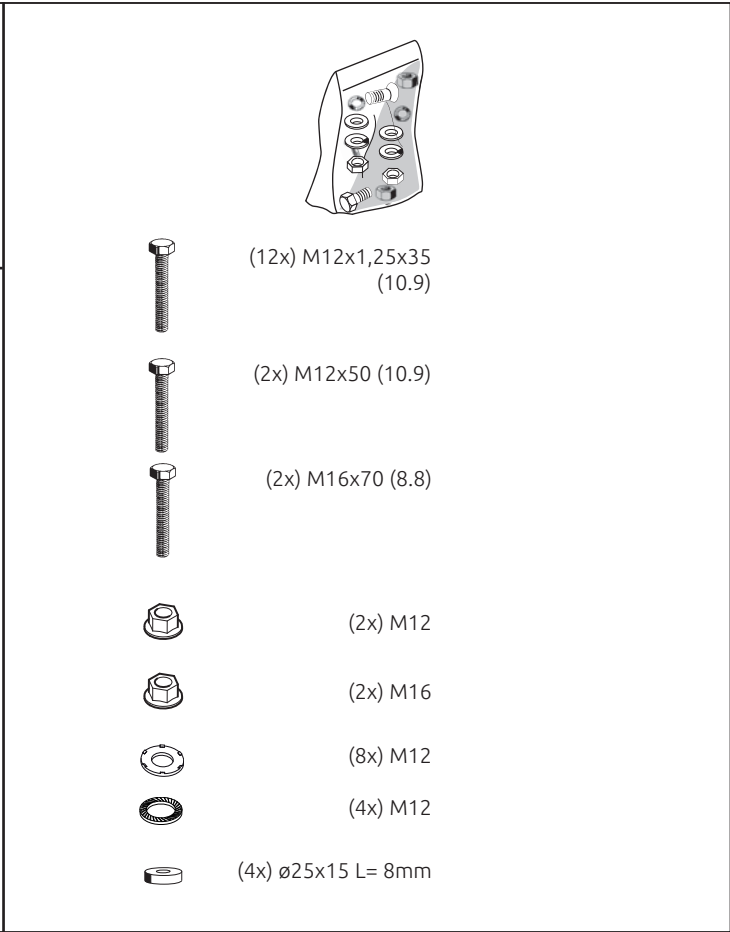
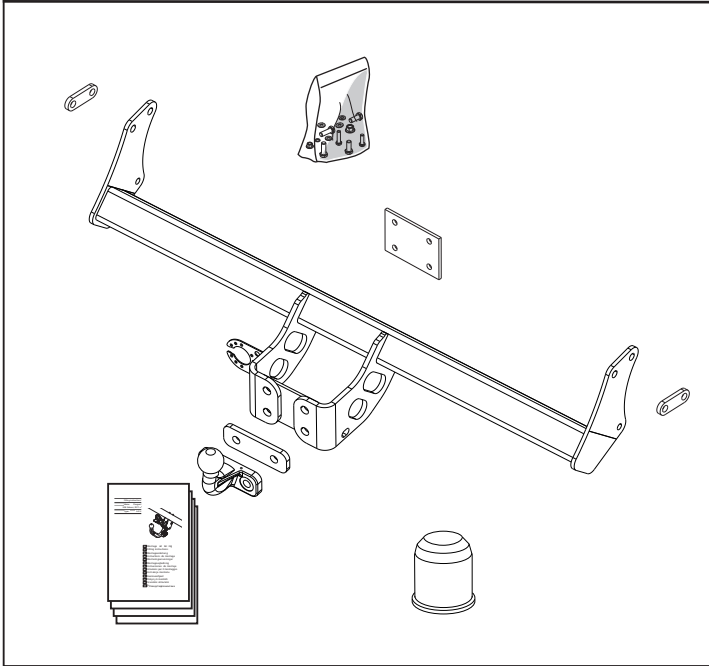
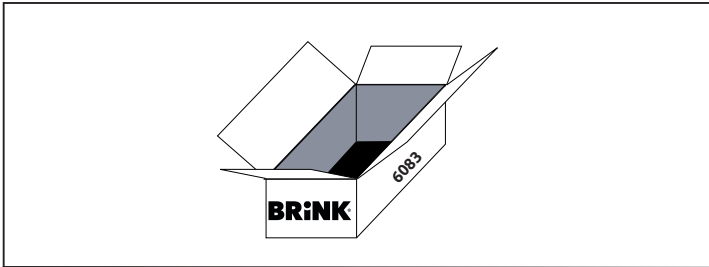

© 608370/02-09-2016/3

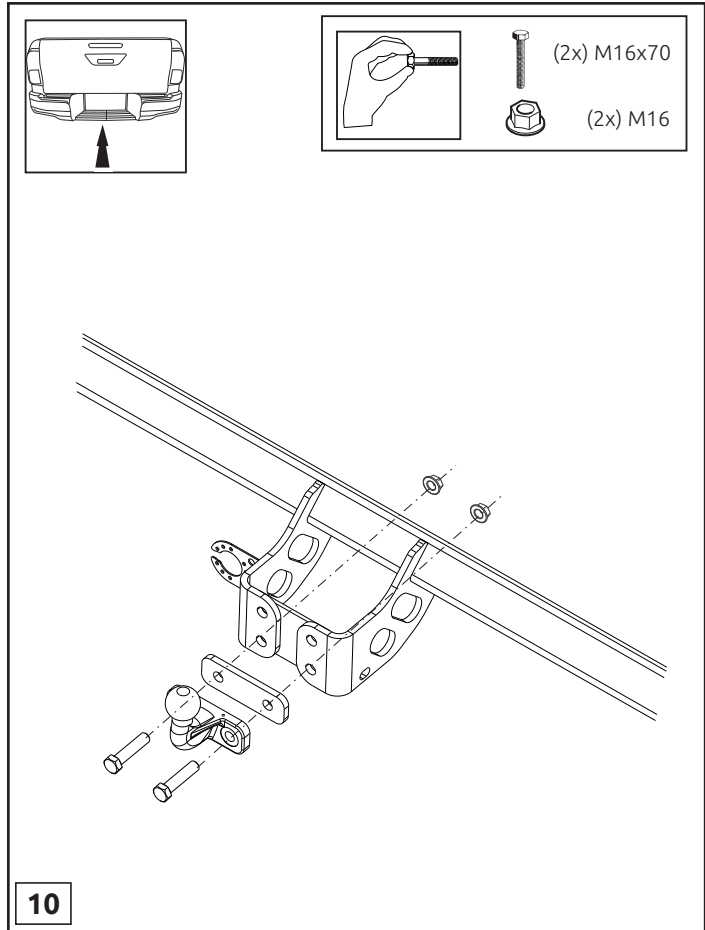
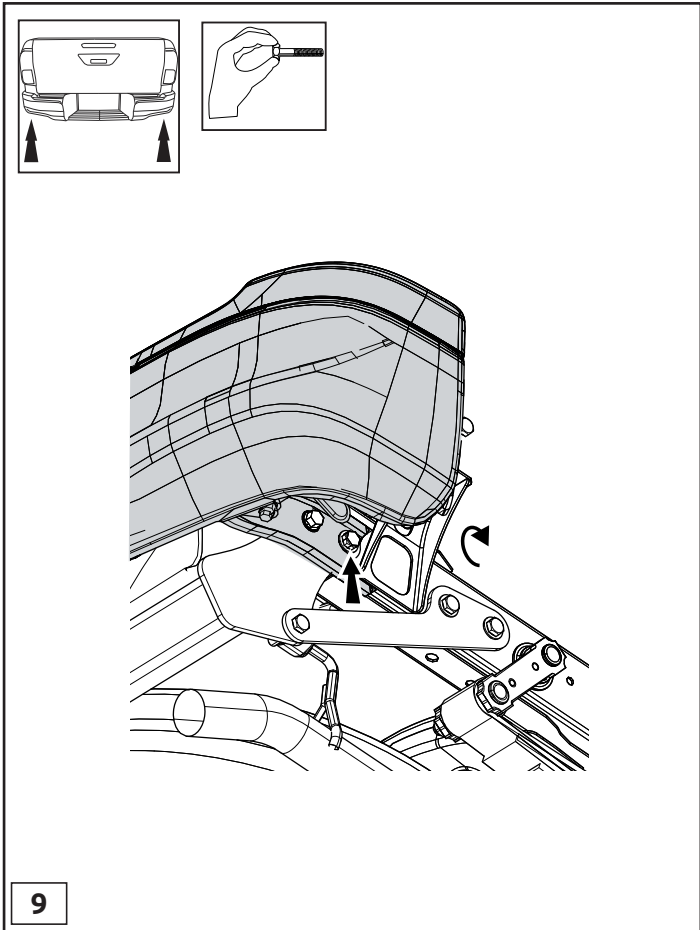

© 608370/02-09-2016/12

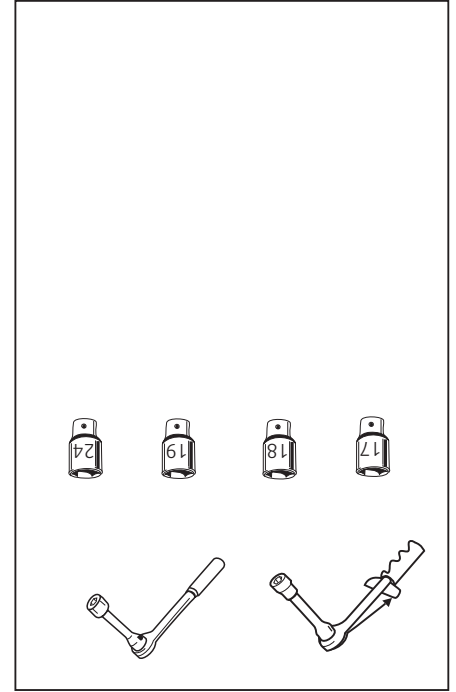
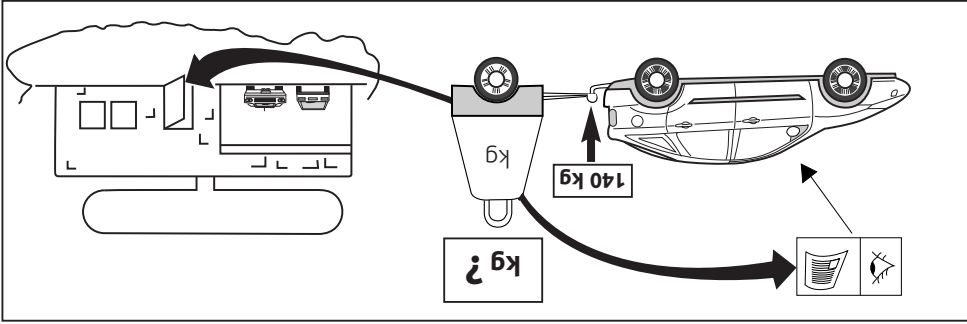
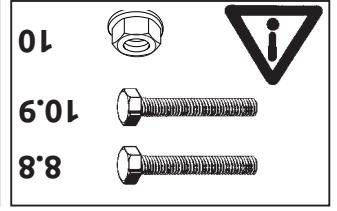
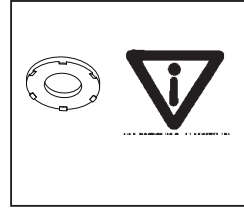
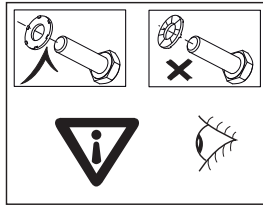
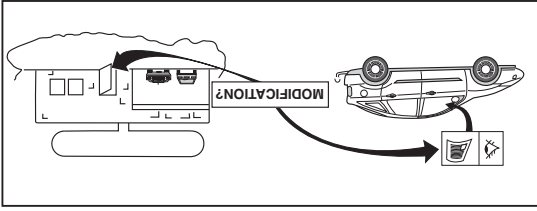

D-Value : 17,2 kN

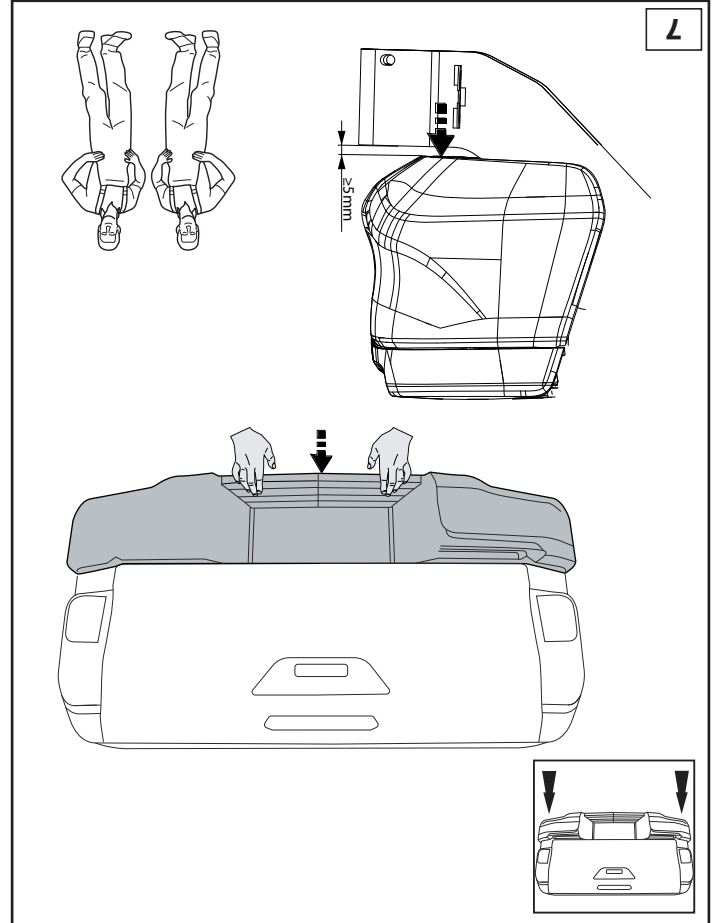
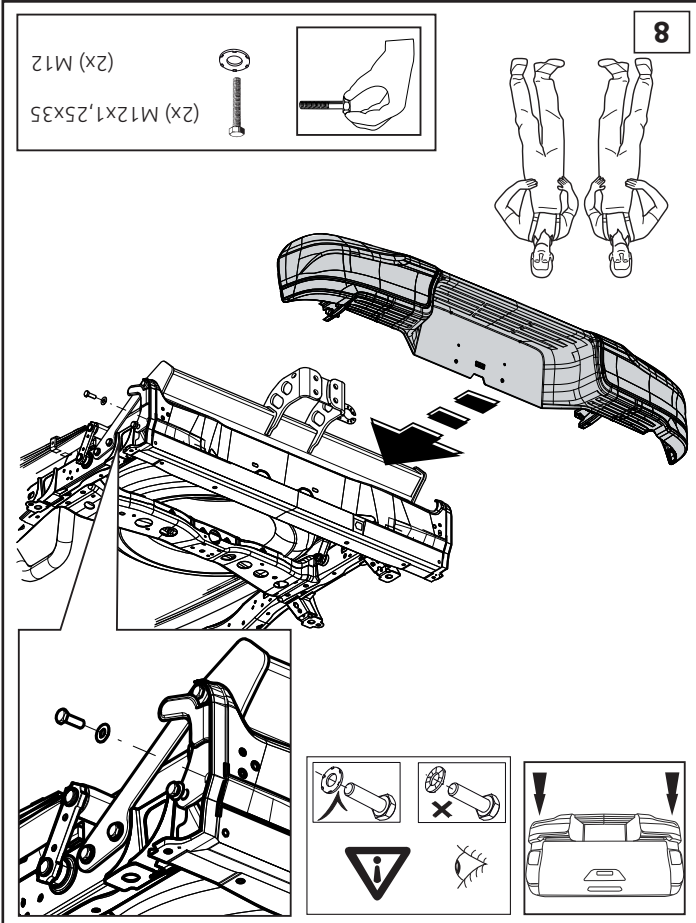
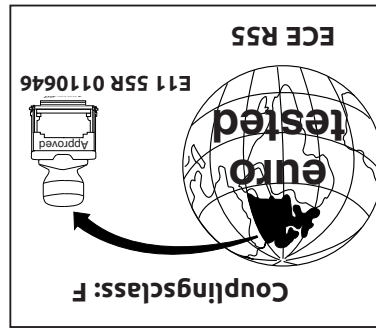

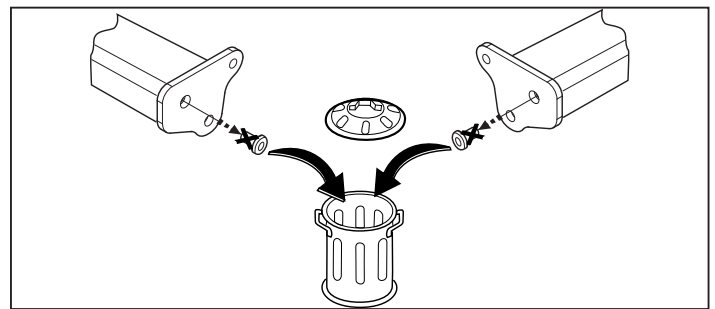
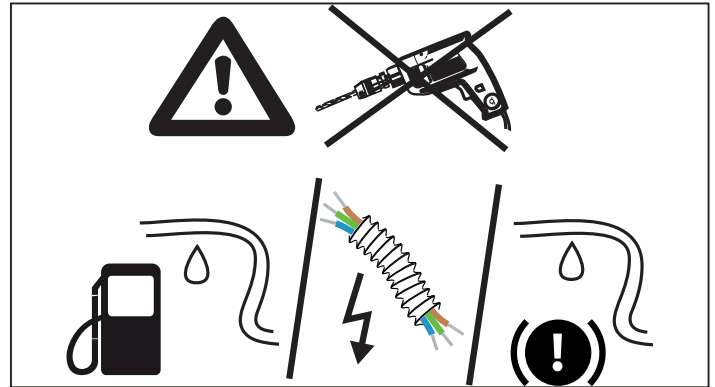
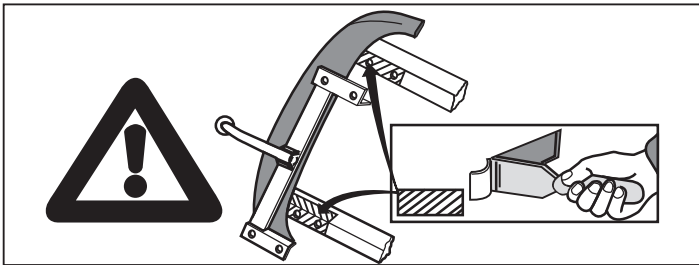
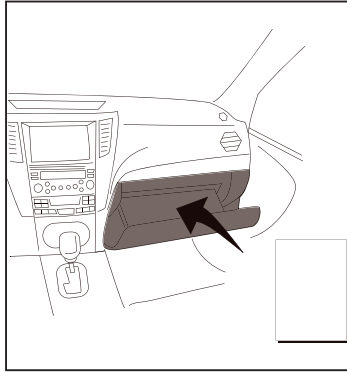
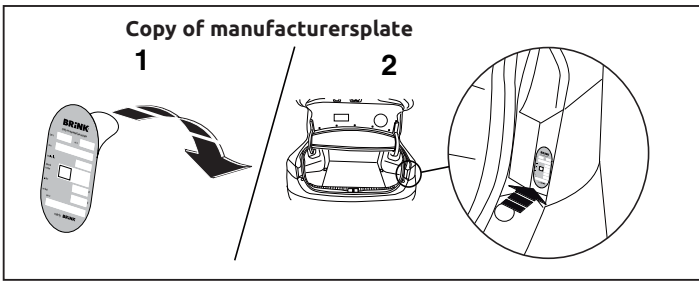

© 608370/02-09-2016/5

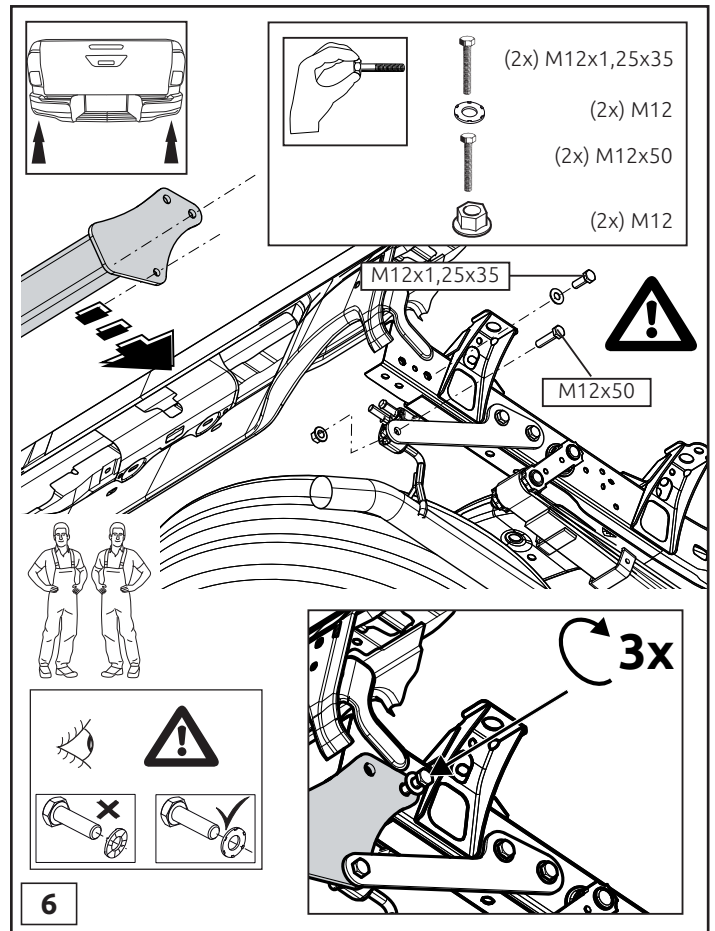
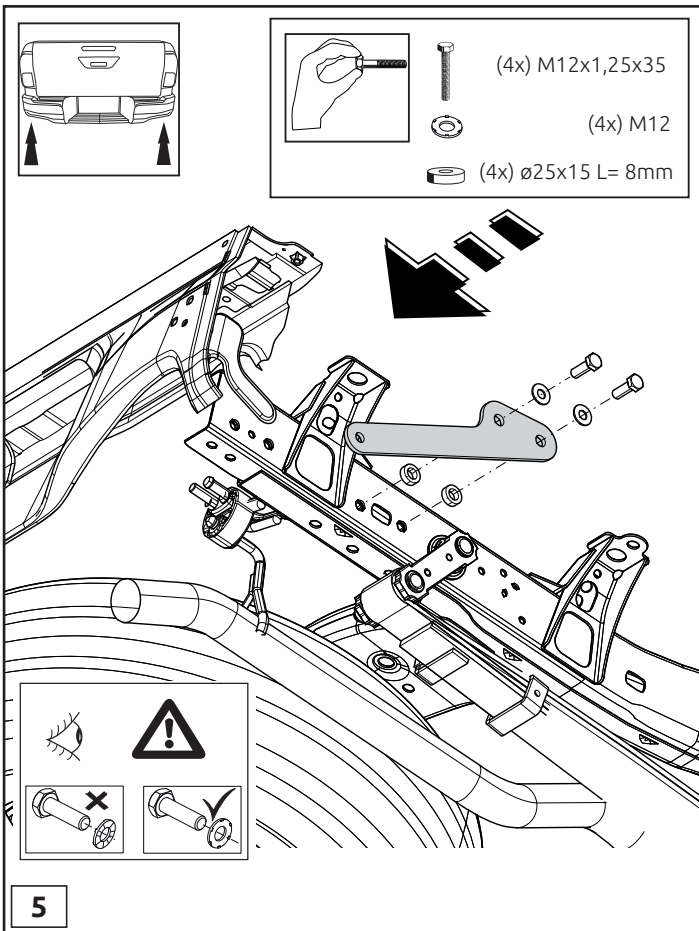

© 608370/02-09-2016/10

* Brink Towing Systems B.V. no se responsabiliza por daños causados, directa o indirectamente, por un montaje incorrecto, incluyendo el uso de herramientas inadecuadas, por el uso de métodos de montaje y medios distintos a los indicados y por la interpretación incorrecta de estas instrucciones de montaje.

* Brink Towing Systems B.V. er ikke ansvarlig for skade der direkte eller indirekte er forårsaget af forkert montage, herunder også iberegnet brug af forkert værktøj og anvendelse af anden montage metode og andre montage midler end de foreskrevne samt fejltilkniing af den medfølgende montagevejledning.

* Brink Towing Systems B.V. är inte ansvariga för skada som orsakats direkt eller indirekt av felaktig montering, inklusive användning av olämpliga verktyg, andra monteringsmetoder och processer än de som beskrivs, samt felaktig tillkniing av dessa monteringsinstruktioner.

* Brink Towing Systems B.V. décline toute responsabilité pour les dommages qui pourraient directement ou indirectement résulter d'un montage incorrect, y compris l'utilisation d'outils inappropriés et l'utilisation d'un mode d'emploi et de moyens autres que ceux prescrits, ou bien résulter d'une interprétation inexacte des présentes instructions de montage.

sowie eine fehlerhafte Interpretation der betreffenden Montageanweisung.

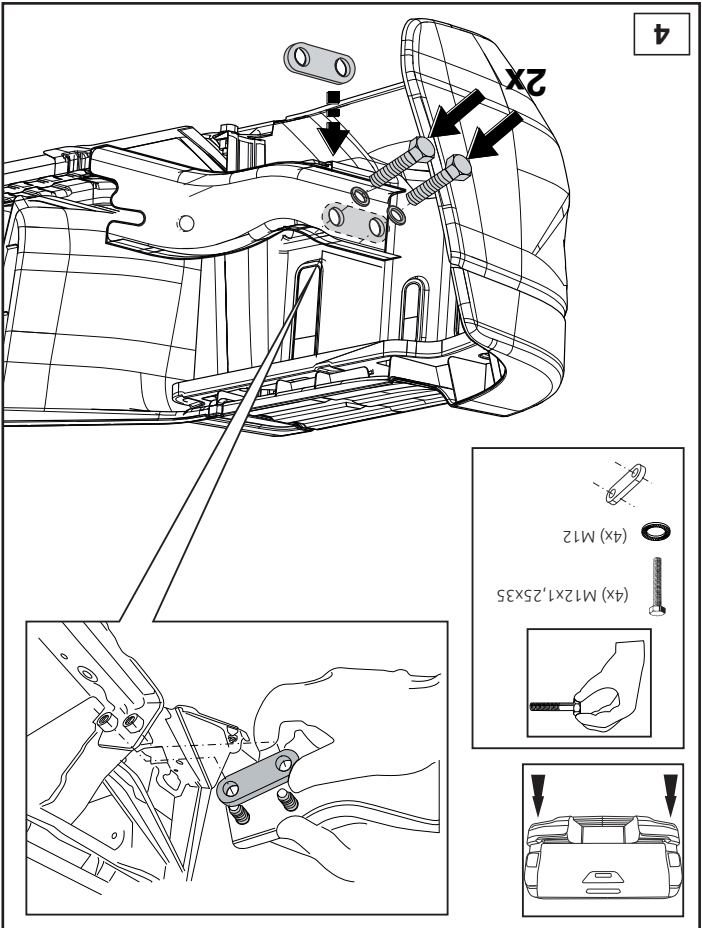

* Die für das Fahrzeug zugelassene Anhängelast ist den Fahrzeug Unterlagen zu entnehmen. Bei Änderungen des Fahrzeuggewichtes muß die höchstzulässige Anhängelast gegebenenfalls aus dem D-Wert nachgerechnet werden. Auskunft hierüber kann Ihr Fachhändler oder der TÜV geben. Elektrische Anlage gemäß StVZO anbringen. Brink Towing Systems B.V. haftet nicht für Schäden, die als direkte oder indirekte Folge einer nicht ordnungsgemäßen Montage auftreten, darunter fallen auch die Benutzung von ungeeigneten Werkzeugen, andere als die vorgeschriebenen Montageverfahren und Montagemittel

* Brink Towing Systems B.V. is not liable for damage caused directly or indirectly by incorrect assembly, including the use of unsuitable tools, the use of other assembly methods and means than the ones outlined, and the incorrect interpretation of these assembly instructions.

* Should this installation process entail the cutting of the bumper – confirmation MUST be obtained by the installation engineer of the customer's acceptance prior to completion. Brink Towing Systems B.V. do not accept responsibility for any matters arising as a result of this miscommunication.

* Brink Towing Systems B.V. is niet aansprakelijk voor de schade die het direct of indirect gevolg is van onjuiste montage, daaronder begrepen gebruik van niet-geschikte gereedschappen en het gebruik van andere dan de voorgeschreven montagewijze en middelen, dan wel onjuiste interpretatie van dit onderhavig montagevoorschrift.

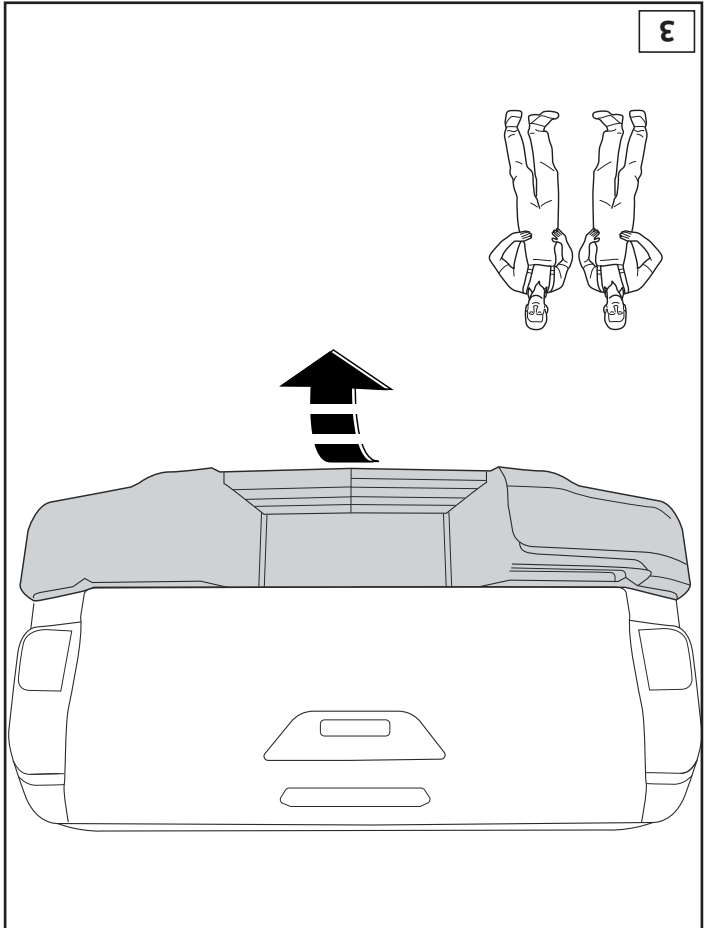

HINWEISE:

D

GB

NL

3

4

I

* Brink Towing Systems B.V. non può essere ritenuta responsabile per eventuali danni direttamente o indirettamente dovuti ad un errato montaggio, intendendo con ciò anche l'uso di attrezzi non idonei e l'uso di metodi e mezzi di montaggio diversi da quelli prescritti, nonché all'errata interpretazione delle seguenti istruzioni di montaggio.

PL

* Brink Towing Systems B.V. nie ponosi odpowiedzialności za straty poniesione pośrednio lub bezpośrednio na skutek niewłaściwego montażu, w tym użycia niewłaściwych narzędzi i sposobów montażu niezgodnych z instrukcją, oraz niezastosowanie się do treści instrukcji.

SF

* Brink Towing Systems B.V. ei ole vastuussa vioittumisesta, joka on suoraan tai epäsuoraan aiheutunut väärästä asennuksesta samoin kuin sopimattomien työkalujen käytöstä, muiden kuin ohjeissa mainittujen asennusmenetelmien tai välineiden käytöstä sekä kyseisten asennusohjeiden väärintulkinnasta.

CZ

* Společnost Brink Towing Systems B.V. neodpovídá za přímé ani nepřímé škody způsobené nesprávnou montáží, včetně použití nevhodných nástrojů, použitím jiných metod montáže a prostředků než uvedených a nesprávným pochopením těchto pokynů k montáži.

H

* A Brink Towing Systems B.V. nem vállal felelősséget a nem megfelelő szerelésből közvetlen vagy közvetett módon következő károkért. Ez vonatkozik a nem megfelelő szerszámok használatára, a leírtaktól eltérő módszerek és eszközök alkalmazására, valamint a szerelési útmutató

téves értelmezésére.

RUS

* Фирма Brink Towing Systems B.V. не отвечает за ущерб, являющийся прямым или косвенным следствием неправильного монтажа, в том числе использования неподходящих инструментов и применения иного способа монтажа или других средств, чем предписано в инструкции, либо неправильного истолкования настоящей инструкции по монтажу.

© 608370/02-09-2016/7

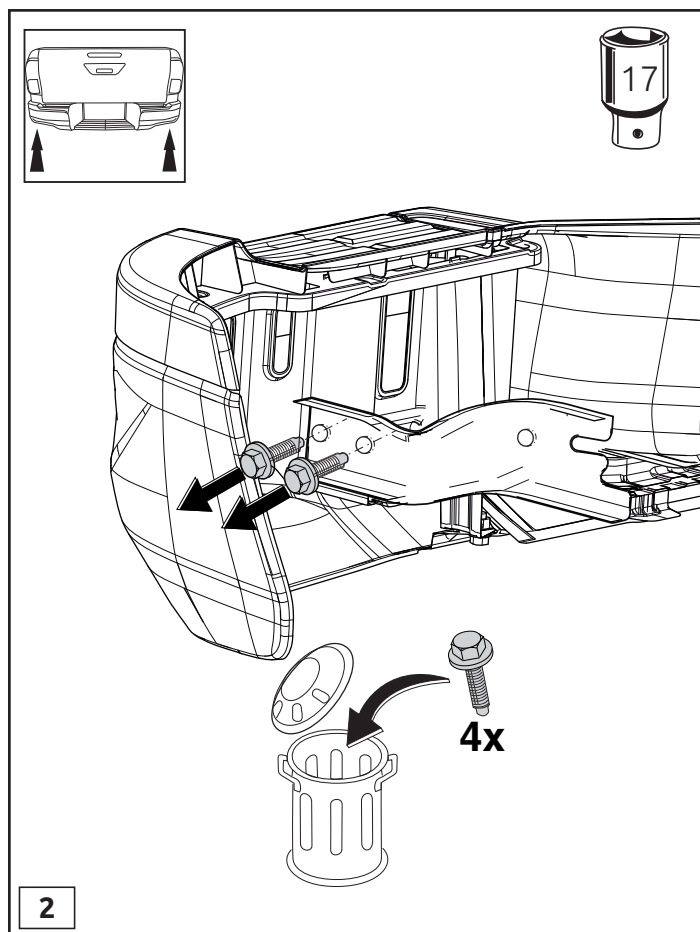
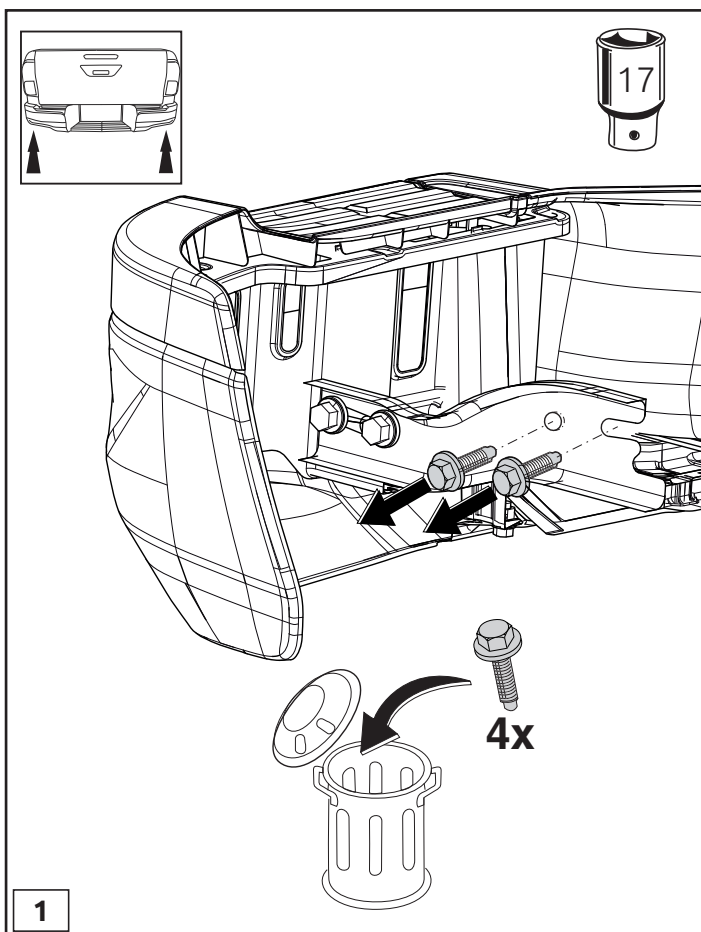

© 608370/02-09-2016/8